

Contents

RENATA – The Swiss power source.....	3
Notice to readers.....	4
Silver oxide coin cells.....	5
Lithium metal coin cells.....	8
Battery holders.....	19
Thin film lithium metal battery	27
Rechargeable lithium-ion coin cells	28
Rechargeable lithium-ion polymer batteries.....	29
Chemistry and construction	32
Electrical & temperature performance.....	33
Passivation phenomena	35
Soldering	36
Frequently Asked Questions (FAQ).....	37
Technical consultancy service	43
Safety guidelines.....	46
Rechargeable lithium-ion polymer batteries guidelines	52
Quality management system	57
Process for the production of lithium metal coin cells	58
Certificates and declarations	59

RENATA – The Swiss power source

Our success story

RENATA SA, with its head office in Itingen near Basel (Switzerland), is a worldwide leading producer and supplier of coin cells for electronic applications. Founded in 1952, RENATA produced mechanical parts for watches, and in the late 70s shifted production to coin cells.

Today, all divisions of RENATA are located in our modern production facility in Itingen, (research and development, production, quality assurance, marketing, logistics, finances and sales).

RENATA has its production plant located in Switzerland, highly automated and with production capabilities well over one million batteries a day. Our production includes silver oxide batteries and 3 V lithium coin cells for watches and industrial applications like medical, telecommunications, and much more. RENATA also supplies rechargeable lithium-ion polymer batteries and zinc air batteries, as well as battery holders for other applications worldwide.

RENATA supplies its products according to its high standards and manages the whole production process: from punched battery housings, over injection molded synthetic seals and the battery components, up to the final assembly. Through this high production expertise, RENATA earned itself a reputation as an extremely flexible and reliable supplier of batteries.

The consistent high quality and power of our coin cells are a result of the reliable quality assurance system we have in place at RENATA. This includes our complete production process – from the inspection of incoming raw materials right through to the testing of the finished product. RENATA is ISO9001 and ISO14001 certified.

RENATA is a subsidiary of The Swatch Group Ltd. in Biel, Switzerland.

Notice to readers

Liability: no Warranties or Representations.

It is the responsibility of each designer and the producer of the battery application to ensure that each system is safe, compatible and adequately designed with all conditions encountered during use, and is in conformance with existing standards and requirements.

Any circuits contained herein are illustrative only, and each user must ensure that each circuit is safe and otherwise completely appropriate for the planned application.

This literature contains information concerning batteries and battery holders marketed by RENATA SA, Switzerland. This information is descriptive only and provided on a «as is» basis, without any warranty or representation of any kind, either express or implied. To full extent permitted by law, RENATA SA disclaims any representations and warranties, including warranties of merchantability and fitness for a particular purpose.

RENATA SA shall not be liable in any manner whatsoever for direct, indirect, incidental or consequential damage, loss of data, income or profit, punitive damages and/or claims of third parties resulting from the use of, access to, or inability to use the information and/or the products described herein.

Battery and battery holder designs are subject to modification without notice.

Silver oxide coin cells

Introduction

In close cooperation with our partners, we have developed low cost, premium quality batteries for numerous industrial applications. Our portfolio includes more than 40 different types of silver oxide batteries classified into three versions of coin cells, High drain, Low drain and an Improved High drain (High Pulse). Our silver oxide batteries are available in a very small format from a diameter of 4.8 mm and a height of 1.25 mm. These cells are optimally suited for very compact and ergonomic applications, such as in Constant Glucose Monitoring (CGM) systems, smart patches and wearable sensors. Our newly developed high-pulse silver oxide batteries are designed to be used in medical applications with wireless transmission, as well as other applications, and they are able to support high current pulses of 10 mA and more.

At RENATA, we have the capability to offer batteries that can meet our customer's particular requirements and performance for a specific application and we can add assemblies composed of several cells and/or tab configurations. Multiple-cell assemblies using parallel circuitry have a greater capacity and pulse-capability, and a lower internal resistance.

The most important parameters for the use of primary coin cells are the load currents, cut-off voltage, temperature profile and the service life. Every current pulse generates a voltage drop, which is dependent on the internal resistance of the battery.

Our competent consultation and the high performance of our batteries ensure that the offered battery design will reliably provide the required performance, even at very low temperatures with batteries of a particular age.

RENATA has first-hand knowledge of what a high quality silver oxide cell must stand for:

- An optimized volume/capacity ratio
- Dimensional precision and stability
- High capacity retention on storage (low self-discharge)
- Excellent reliability thanks to a uniformly high quality level
- State of the art leak-proof thanks to a sophisticated sealing process.

General characteristics

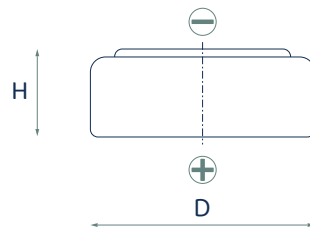

- Nominal voltage: 1.55 V
- Operating temperature: -10 °C to 60 °C
- Low drain type cells are oriented to applications with continuous, low power consumption
- High drain type cells are oriented to applications with a continuous, low power consumption and/or occasional high peak currents.
- Self-discharge per year at 20 °C:
 - Low drain type cells: less than 5% per year
 - High drain type cells: less than 10% per year

Silver oxide coin cells

Low drain batteries

Model	Capacity [mAh]	Diameter [mm]	Height [mm]
335	6.0	5.8	1.2
337	8.0	4.8	1.6
346	9.5	7.9	1.2
317	10.5	5.8	1.6
339	11.0	6.8	1.4
321	14.5	6.8	1.6
341	15.0	7.9	1.4
379	16.0	5.8	2.1
364	20.0	6.8	2.1
319	21.0	5.8	2.7
315	23.0	7.9	1.6
362	24.0	7.9	2.1
377	28.0	6.8	2.6
373	29.0	9.5	1.6
397	32.0	7.9	2.6
329	37.0	7.9	3.1
371	40.0	9.5	2.0
384	45.0	7.9	3.6
366	47.0	11.6	1.6
381	50.0	11.6	2.1
395	55.0	9.5	2.7
390	60.0	11.6	3.1
309	80.0	7.9	5.4
394	84.0	9.5	3.6
344	105.0	11.6	3.6
301	130.0	11.6	4.2
303	175.0	11.6	5.4

High drain batteries

Model	Capacity [mAh]	Diameter [mm]	Height [mm]
361	24	7.9	2.1
376	27	6.8	2.6
396	32	7.9	2.6
370	40	9.5	2.0
392	45	7.9	3.6
365	47	9.5	1.6
391	50	11.6	2.1
399	53	9.5	2.7
393	80	7.9	5.4
389	80	11.6	3.1
380	82	9.5	3.6
350	105	11.6	3.6
386	130	11.6	4.2
357	160	11.6	5.4

Silver oxide coin cells

Standard bare coin cells – Packaging options

Coin cells can be supplied in different packaging.

Industrial bulk multi-cell plastic trays

Packaging Code: IB

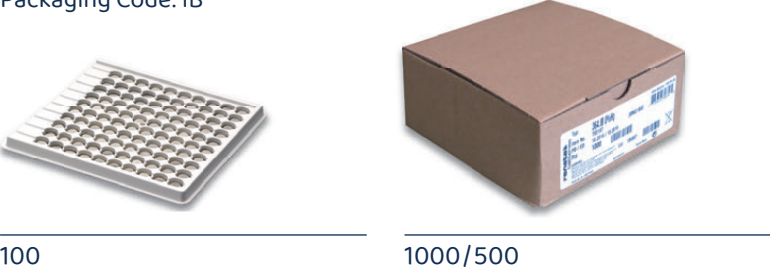

100

1000/500

Industrial Bulk packaging is the standard packaging for manufacturers. There are 100 coin cells per plastic tray, and 5 to 10 plastic trays per shrink pack depending on customer request.

Multipack coin cells in blister

Packaging code: MP



10

100/100

Multipack coin cells are used in replacement and retail business. There are ten coin cells in a multipack blister, and ten blisters in a small box.

Single packaged coin cells in blistered secure card units

Packaging Code: CU



1

10/30

300/900

Secure card packaging are used in replacement and retail business. There is one coin cell in a secure card unit, ten or thirty secure cards in a small box depending on cell type, and thirty small boxes in a bigger box.

Visit our website www.renata.com for further information.

Lithium metal coin cells

Introduction

Since 1982, when RENATA launched the industrial production of lithium batteries, the range of applications has grown continuously. RENATA lithium batteries are used for different applications such as in computers, telecommunications, and medical industry and in an increasing number of portable devices such as measuring equipment, payment systems, toys etc.

RENATA lithium batteries meet the highest quality standards and offer excellent reliability.

Advantages

- Nominal voltage of 3 V, approx. twice the voltage level of alkaline coin cells
- Wide operating temperature range depending on battery model
- Low self-discharge of less than 1% per year at 23 °C
- Optimized energy/volume ratio
- Improved leakage resistance
- Excellent storage characteristics
- Available in a wide range of solder contact configurations or in combination with our battery holders

Lithium metal coin cells

Standard bare coin cells

General characteristics

- Shelf life:
 - Cells with diameter between 10 mm and 12 mm – up to 5 years at max. 23 °C
 - Cells with diameter between 16 mm and 24 mm – up to 7 years at max. 23 °C
- Stable voltage during shelf life
- High reliability of operation, including leakage resistance

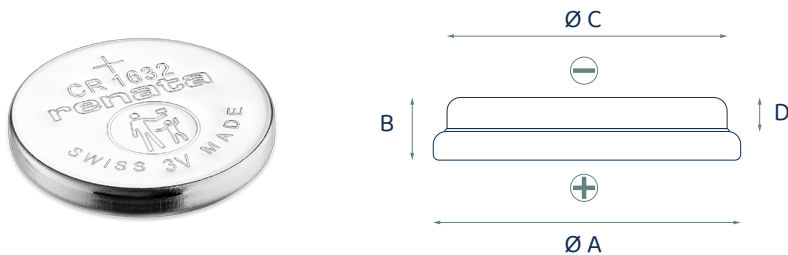

Dimensions, weights and electrical characteristics

Max. Dimensions [mm]

Model	A	B	C	D	Approx. Weight [g]	Nominal capacity [mAh]	Standard discharge current [mA]	Max. Continuous discharge current [mA]	Operating temperature [°C]	Self-Discharge at 23 °C
CR1025	10.0	2.50	6.0	min 0.08	0.6	30	0.05	0.40	-40/+85	<1.0%
CR1216 MFR	12.5	1.60	10.2	min 0.05	0.7	25	0.10	1.00	-30/+85	<1.0%
CR1220 MFR	12.5	2.00	10.3	min 0.10	0.9	35	0.10	1.00	-30/+85	<1.0%
CR1225	12.5	2.50	9.0	min 0.08	0.9	48	0.10	1.00	-40/+85	<1.0%
CR1616	16.0	1.60	12.0	min 0.02	1.1	50	0.10	1.00	-40/+85	<1.0%
CR1620	16.0	2.00	12.0	min 0.06	1.2	68	0.10	1.00	-40/+85	<1.0%
CR1632	16.0	3.20	12.0	min 0.08	1.8	137	0.20	1.50	-40/+85	<1.0%
CR2016 MFR	20.0	1.60	18.0	min 0.05	1.7	90	0.20	3.00	-30/+85	<1.0%
CR2016.MFR	20.0	1.60	14.0	min 0.15	1.7	104	0.20	3.00	-30/+70	~1.5%
CR2025 MFR	20.0	2.50	17.0	min 0.05	2.5	165	0.30	3.00	-30/+85	<1.0%
CR2025.MFR	20.0	2.50	14.0	min 0.15	2.4	180	0.30	3.00	-30/+70	<1.5%
CR2032 MFR	20.0	3.20	17.0	min 0.05	2.8	225	0.40	3.00	-30/+85	<1.0%
CR2032.MFR	20.0	3.20	18.0	min 0.06	2.9	260	0.40	3.00	-30/+70	<1.5%
CR2320	23.0	2.00	18.0	min 0.06	2.7	150	0.20	3.00	-40/+85	<1.0%
CR2325	23.0	2.50	19.0	min 0.08	3.0	190	0.30	3.00	-40/+85	<1.0%
CR2430	24.5	3.00	20.0	min 0.08	4.1	285	0.50	4.00	-40/+85	<1.0%
CR2450N	24.5	5.00	22.3	min 2.50	5.9	540	0.80	3.00	-40/+85	<1.0%
CR2450N-MFR	24.5	5.00	22.3	min 2.50	5.9	580	1.30	3.00	-40/+85	<1.0%
CR2477N	24.5	7.70	22.4	min 5.30	8.3	950	1.00	2.50	-40/+85	<1.0%

- The maximum current is determined for a yield of 70% of the nominal capacity with a cut-off voltage of 2.0 V, at 23 °C. For currents exceeding those given above or pulsed current, please contact RENATA.
- In applications where the battery is exposed to temperatures above 70 °C, please contact RENATA for consultancy.

Lithium metal coin cells

Standard bare coin cells

CR2032 MFR 

Rated capacity: 225 mAh

Average weight: 2.8 g

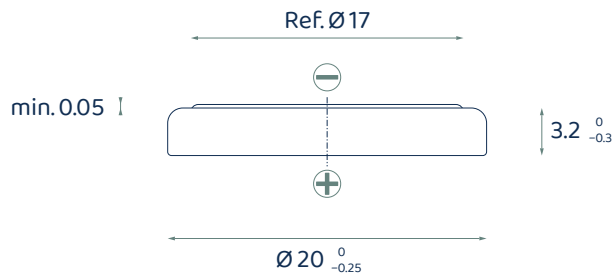

Discharge performance at 23 °C

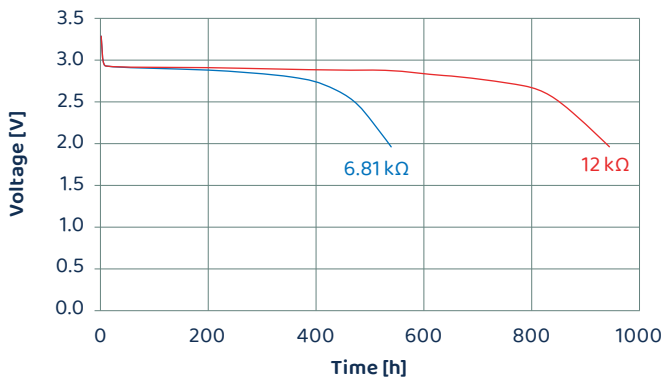

Discharge performance at 23 °C

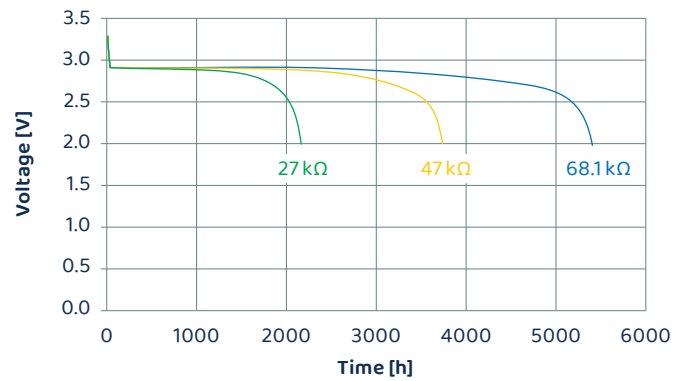

Temperature performance – Load 12 kΩ

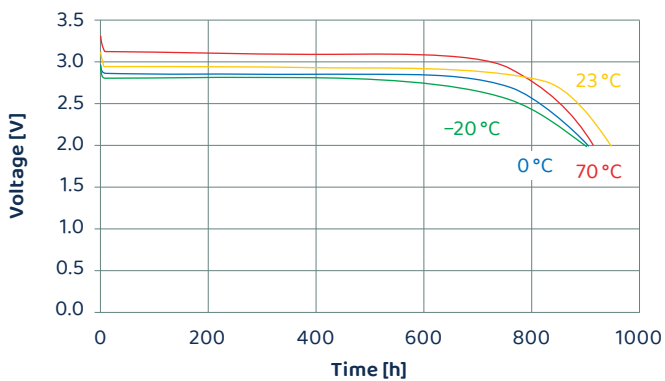

Cell capacity at various loads

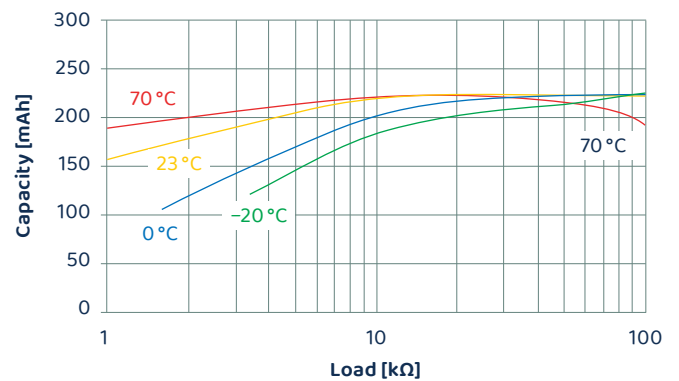

Lithium metal coin cells

Standard bare coin cells – Packaging options

Coin cells can be supplied in different packaging formats.

Industrial bulk multi-cell plastic trays

Packaging Code: IB



25/50/100

Industrial Bulk packaging is the standard packaging for manufacturers.

The number of coin cells per plastic tray depends on the respective model (25/50/100).

So does the number of plastic trays per shrink pack.

Single packaged coin cells in blistered secure cards

Packaging Code: SC



1

6/10

300/180

Secure card packaging is mainly used in replacement and retail business. There is one coin cell in a Card Unit, six to ten Secure cards in a small box depending on the cell size, and ten small boxes in a bigger box.

Lithium metal coin cells

Coin cells with tabs

Horizontal assembly with two pins

Catalogue of two pin standard tabbed coin cells for horizontal mounting on PCBs.

Features

- Excellent solderability thanks to solder plated areas
- Suitable for wave soldering

Specifications

- Solder contacts stainless steel AISI 301, thickness 0.15 mm
- Tin-plated solder area lead free (>99.9% Sn) plated throughout, thickness min. 2.5 µm.
Solderability according to MIL-STD 883C, method 2003.3

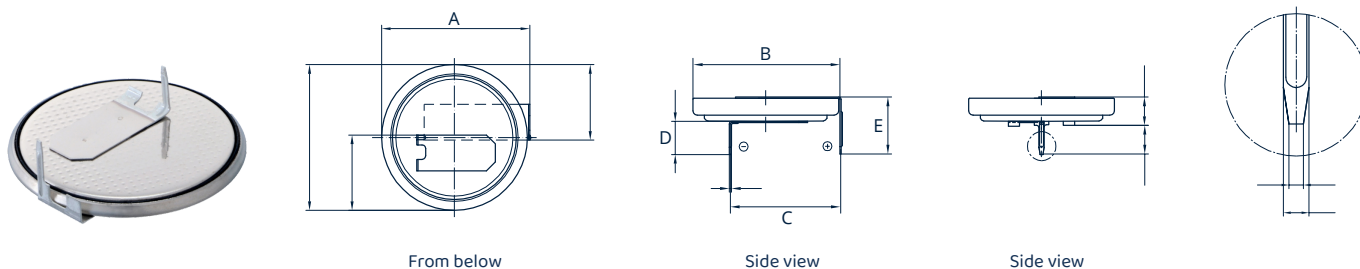

Dimensions [mm]

RENATA part name	Nominal capacity [mAh]	A	B	C	D	E	Weight [g]
CR1216 MFR FH	25	12.5	12.85	11.00	2.4	6.3	1.0
CR1220 MFR FH	35	12.5	12.85	11.00	2.8	6.7	1.1
CR1225FH-LF	48	12.5	12.85	11.00	3.3	7.2	1.1
CR1616FH-LF	50	16.0	16.35	12.70	2.4	6.3	1.3
CR1620FH-LF	68	16.0	16.35	12.70	2.8	6.7	1.4
CR1632FH-LF	137	16.0	16.35	11.00	3.9	7.8	2.0
CR1632FH1-LF	137	16.0	16.35	15.20	3.9	7.8	2.0
CR2016 MFR FH	90	20.0	20.35	15.20	2.4	6.3	1.9
CR2016 MFR FH1	90	20.0	20.35	20.40	2.4	6.3	1.9
CR2025 MFR FH	165	20.0	20.35	15.20	3.3	7.2	2.7
CR2025 MFR FH1	165	20.0	20.35	20.40	3.3	7.2	2.7
CR2032 MFR FH	225	20.0	20.35	15.20	3.9	7.8	3.0
CR2032 MFR FH0	225	20.0	20.35	10.35	3.9	7.8	3.0
CR2032 MFR FH1	225	20.0	20.35	20.40	3.9	7.8	3.0
CR2032MFR FH2	225	20.0	20.35	22.50	3.9	7.8	3.0
CR2325FH-LF	190	23.0	23.35	20.40	3.3	3.3	3.2
CR2430FH-LF	285	24.5	24.75	20.40	3.9	7.8	4.3
CR2430FH1-LF	285	24.5	24.85	15.20	3.9	7.8	4.3
CR2450NFH-LF	540	24.5	24.85	20.40	5.8	9.7	6.1
CR2477NFH-LF	950	24.5	24.85	20.40	8.5	12.4	8.4

Lithium metal coin cells

Coin cells with tabs

Horizontal surface mounting assembly with 2 tabs (SM types)

Catalogue of SM tabbed coin cells for horizontal mounting on PCBs.

Features

- Good solderability

Specifications

- Tab material: Isotan (54 % Cu, 44 % Ni, Mn)

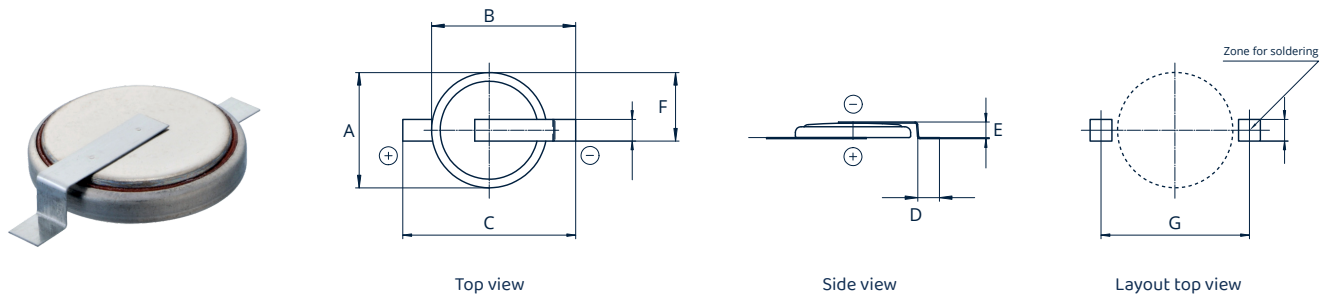

Dimensions [mm]

RENATA part name	Nominal capacity [mAh]	A	B	C	D	E	F	G	Weight [g]
CR1025SM	30	10.0	13.0	16.0	2.0	2.8	6.5	14.0	0.8
CR1216 MFR SM	25	12.5	15.75	19.0	2.0	1.9	7.75	17.0	1.0
CR1220 MFR SM	35	12.5	15.75	19.0	2.0	2.3	7.75	17.0	1.1
CR1225SM	48	12.5	15.75	19.0	2.0	2.8	7.75	17.0	1.2
CR1616SM	50	16.0	20.0	24.0	3.0	1.9	9.5	21.0	1.3
CR1620SM	68	16.0	20.0	24.0	3.0	2.3	9.5	21.0	1.4
CR1632SM	137	16.0	20.0	24.0	3.0	3.5	9.5	21.0	2.0
CR2016 MFR SM	90	20.0	24.0	28.0	3.0	1.9	11.5	25.0	1.9
CR2025 MFR SM	165	20.0	24.0	28.0	3.0	2.8	11.5	25.0	2.7
CR2032 MFR SM	225	20.0	24.0	28.0	3.0	3.5	11.5	25.0	3.0
CR2320SM	150	23.0	28.0	33.0	4.0	2.3	13.0	29.0	2.9
CR2325SM	190	23.0	28.0	33.0	4.0	2.8	13.0	29.0	3.2
CR2430SM	285	24.5	29.5	34.5	4.0	3.3	13.75	30.5	4.3
CR2450N SM	540	24.5	29.5	34.5	4.0	5.3	13.75	30.5	6.1
CR2477N SM	950	24.5	29.5	34.5	4.0	8.0	13.75	30.5	8.4

Lithium metal coin cells

Coin cells with tabs

Horizontal assembly with three pins

Catalogue of two-pin standard tabbed coin cells for horizontal mounting on PCBs.

Features

- Excellent solderability thanks to solder-plated areas
- Suitable for wave-soldering

Specifications

- Solder contacts stainless steel AISI 301, thickness 0.15 mm
- Tin-plated solder area lead free (>99.9% Sn) plated throughout, thickness min. 2.5 µm.
Solderability according to MIL-STD 883C, method 2003.3

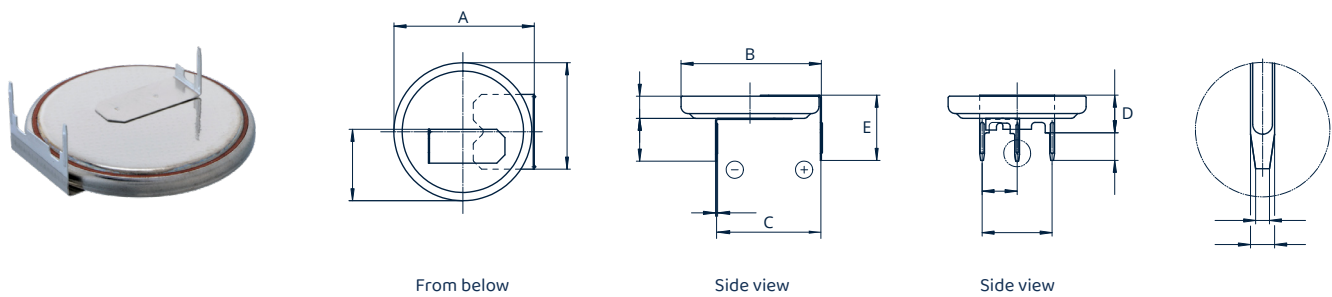

Dimensions [mm]

RENATA part name	Nominal capacity [mAh]	A	B	C	D	E	Weight [g]
CR1632RH-LF	137	16.0	16.35	15.2	5.45	9.45	2.0
CR2016 MFR RH	90	20.0	20.35	15.2	3.95	7.95	2.0
CR2025 MFR RH	165	20.0	20.35	15.2	4.85	8.85	2.6
CR2032 MFR RH	225	20.0	20.35	15.2	5.45	9.45	3.1
CR2032 MFR RH1	225	20.0	20.35	17.8	5.45	9.45	3.1
CR2032 MFR RH2	225	20.0	20.35	20.4	5.45	9.45	3.0
CR2325RH-LF	190	23.0	23.35	17.8	4.85	8.85	3.3
CR2430RH-LF	285	24.5	24.85	17.8	5.45	9.45	4.4
CR2430RH1-LF	285	24.5	24.85	20.4	5.45	9.45	4.4
CR2450NRH-LF	540	24.5	24.85	17.8	7.35	11.35	6.2
CR2450RH1-LF	540	24.5	24.85	20.4	7.35	11.35	6.2
CR2477NRH-LF	950	24.5	24.85	17.8	10.05	14.05	8.5

Lithium metal coin cells

Coin cells with tabs

Vertical assembly with two pins

Catalogue of two-pin standard tabbed coin cells for vertical mounting on PCBs.

Features

- Excellent solderability thanks to solder-plated areas
- Suitable for wave-soldering

Specifications

- Solder contacts stainless steel AISI 301, thickness 0.15 mm
- Tin-plated solder area plated throughout, thickness min. 2.5 µm.
Solderability according to MIL-STD 883C, method 2003.3

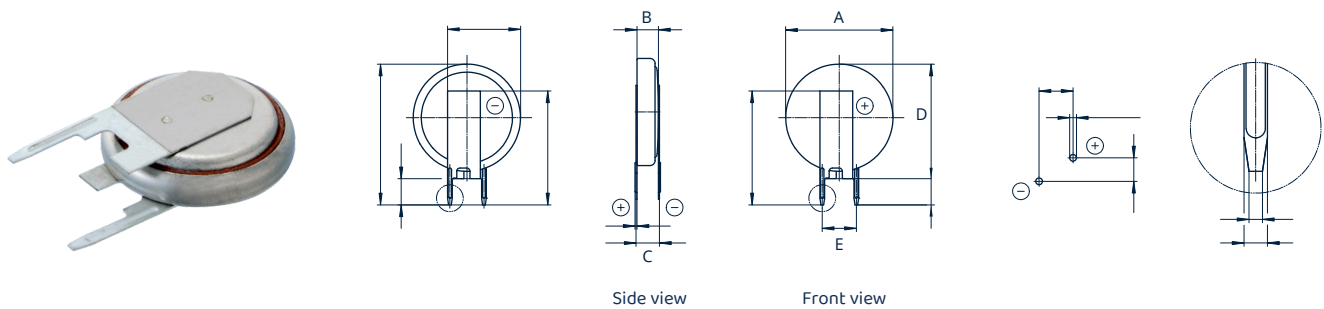

Dimensions [mm]

RENATA part name	Nominal capacity [mAh]	A	B	C	D	E	Weight [g]
CR1025FV-LF	30	10.0	2.5	2.8	11.0	5.08	0.8
CR1025FV1-LF	30	10.0	2.5	2.8	11.0	5.08	0.8
CR1216 MFR FV	25	12.5	1.6	1.9	13.6	5.08	1.0
CR1220 MFR FV	35	12.5	2.0	2.3	13.6	5.08	1.1
CR1225FV-LF	48	12.5	2.5	2.8	13.5	5.08	1.1
CR1616FV-LF	50	16.0	1.6	1.9	17.0	5.08	1.3
CR1620FV-LF	68	16.0	2.0	2.3	17.0	5.08	1.4
CR1632FV-LF	137	16.0	3.2	3.5	17.0	5.08	2.0
CR2016 MFR FV	90	20.0	1.6	1.6	21.1	10.5	2.0
CR2032 MFR FV	225	20.0	3.2	3.5	21.0	10.5	3.0
CR2320FV-LF	150	23.0	2.0	2.3	24.0	10.5	2.9
CR2325FV-LF	190	23.0	2.5	2.8	24.0	10.5	3.2
CR2430FV-LF	285	24.5	3.0	3.3	25.5	10.5	4.3
CR2450NFV-LF	540	24.5	5.0	5.8	25.5	10.5	6.1
CR2477NFV-LF	950	24.5	7.7	8.0	25.5	10.5	8.4

Lithium metal coin cells

Coin cells with tabs

Three pins vertical mounting

Catalogue of three-pin standard tabbed coin cells for vertical mounting on PCBs.

Features

- Excellent solderability thanks to solder-plated areas
- Suitable for wave-soldering

Specifications

- Solder contacts stainless steel AISI 301, thickness 0.15 mm
- Tin-plated solder area plated throughout, thickness min. 2.5 μm .
Solderability according to MIL-STD 883C, method 2003.3

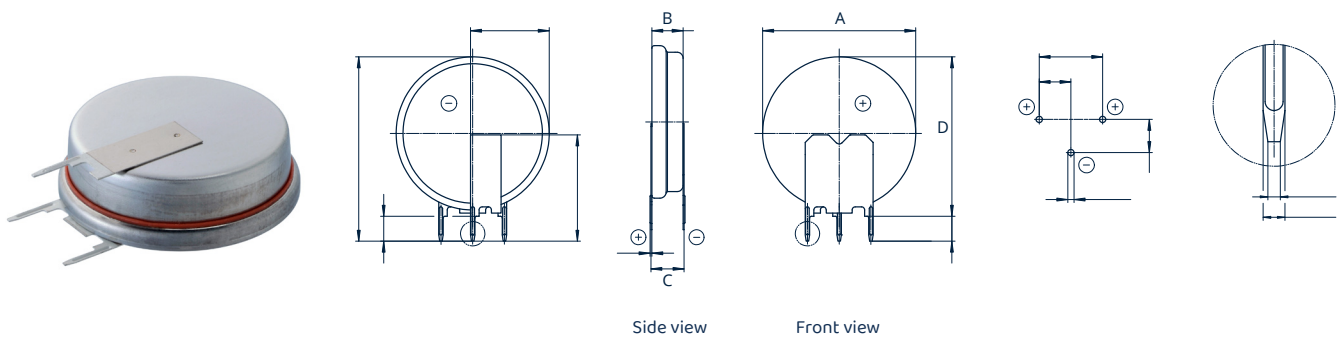

RENATA part name	Nominal capacity [mAh]	Dimensions [mm]				Weight [g]
		A	B	C	D	
CR2025 MFR RV	165	20.0	2.5	2.8	21.0	2.8
CR2032 MFR RV	225	20.0	3.2	3.5	21.0	3.1
CR2325RV-LF	190	23.0	2.5	2.8	24.0	3.3
CR2430RV-LF	285	24.5	3.0	3.3	25.5	4.4
CR2450NRV-LF	540	24.5	5.0	5.3	25.5	6.2
CR2477NRV-LF	950	24.5	7.7	8.0	25.5	8.5

Lithium metal coin cells

Coin cells with tabs

Horizontal assembly with Isotan¹ pins

Catalogue of two-pins, Isotan¹-tabbed coin cells for horizontal mounting on PCBs.

Features

- Good solderability
- Suitable for wave-soldering

Specifications

- Tab material: Isotan (54% Cu, 44% Ni, Mn)

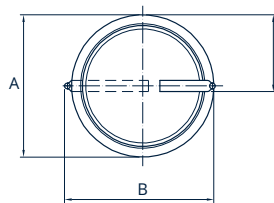

From below

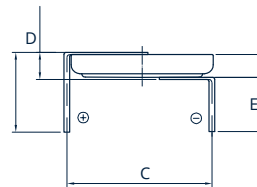

Side view

Dimensions [mm]

RENATA part name	Nominal capacity [mAh]	A	B	C	D	E	Weight [g]
CR1225AH	48	12.50	13.3	11.00	3.10	7.6	1.1
CR1632AH1	137	16.00	17.0	15.20	3.80	7.6	2.0
CR2025 MFR AH	165	20.00	21.0	15.20	3.10	7.6	2.7
CR2032 MFR AH	225	20.00	21.0	15.20	3.85	7.6	3.0
CR2032 MFR AH0	225	20.00	21.0	10.35	3.85	7.6	3.0
CR2032 MFR AH1	225	20.00	21.0	20.40	3.85	7.6	3.0
CR2430AH	285	24.50	25.3	20.40	3.60	7.6	4.3
CR2450NAH	540	24.50	25.3	20.40	5.60	5.6	6.1
CR2477NAH	950	24.50	25.3	20.40	8.30	3.0	8.3

Lithium metal coin cells

Coin cells with tabs – Packaging options

Industrial bulk multi-cell plastic trays

Packaging Code: IB

All tabbed coin cells are supplied in the following packaging:



Industrial Bulk packaging is the standard packaging for manufacturers.

The number of tabbed coin cells per plastic tray depends on the respective model. So does the number of plastic trays per shrink pack.

Battery holders

Surface mounting technology (SMTU) – Horizontal

Features

- Easy and fast replacement of the battery
- Designed for automatic «pick & place» mounting
- Safe retention of coin cell
- Automated battery mounting possible
- Clear separation of connections
- Protection against short-circuits
- Protection against inverse polarity (polarized)
- Protection against leak currents
- Robust design
- Suitable for reflow-soldering

Specifications

- Holder material: heat-resistant, glass fiber filled LCP
- Flammability rating UL 94 V-0
- Battery contacts: spring stainless steel AISI 301, nickel-plated. Solder area tin-plated throughout, min. thickness 5 μm .
- Contact resistance between contacts and the cell is less than 100 m Ω (measured through AC 1 kHz; depending on the case material of the cell).
-  UL recognition, file E218732
- Temperature range: -40/+85 °C

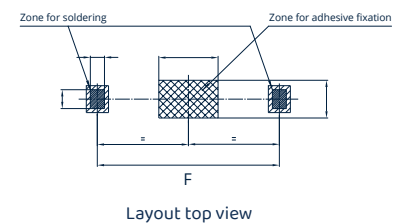
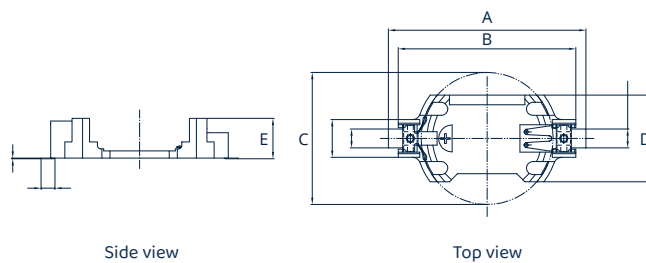
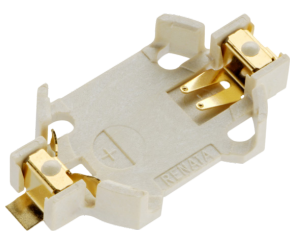

Dimensions [mm]

RENATA part name	For use with RENATA cell	A	B	C	D	E	F	Weight [g]
SMTU357-LF	357	23.6	19.9	11.6	12.0	7.55	20.7	0.85
SMTU1220-LF	CR1220	23.7	20.3	12.5	12.7	4.8	21.1	0.80
SMTU1225-LF	CR1225	23.7	20.3	12.5	12.7	4.8	21.1	0.70
SMTU1632-LF	CR1632	27.7	24.3	16.0	14.5	5.4	25.1	0.80
SMTU2032-LF	CR2032	32.0	28.5	20.0	16.1	5.4	29.4	0.95
SMTU2430-LF	CR2430	36.4	33.0	24.5	16.1	4.9	33.8	1.05
SMTU2450N-LF	CR2450N	36.7	33.0	24.5	16.1	7.5	33.8	1.45
SMTU2477N-LF	CR2477N	36.7	33.0	24.5	16.1	10.3	33.8	1.65
SM2X2016-LF	CR2016	32.0	28.5	20.0	16.1	5.4	29.4	0.95
SMTU2032-G*	CR2032	32.0	28.5	20.0	16.1	5.4	29.4	0.95

*Gold plated contacts for increased conductivity (optional)

Battery holders

Surface mounting metal (SMTM) – Low profile

Features

- Low profile for compact PCBs
- Dual spring contacts for low resistance
- Soldering holes for increased joint strength
- Designed for automatic «pick & place» mounting
- Safe retention of coin cell
- Suitable for reflow soldering

Specifications

- Holder material: Nickel plated phosphor bronze
- Temperature range: -40/+85 °C

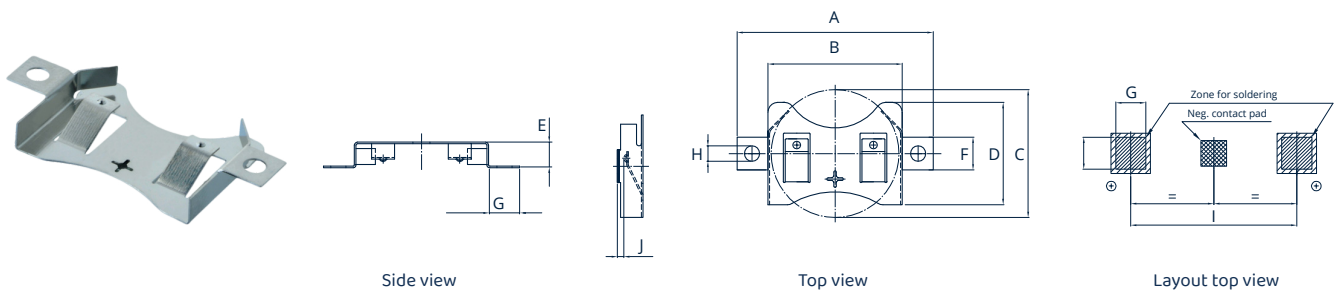

Maximum dimensions [mm]

RENATA part name	For use with cell	A	B	C	D	E	F	G	H	I	J	Weight [g]
SMTM1225	CR1225	18.9	13.2	12.5	10.60	3.2	3.2	3.2	1.2	16.10	1.5	0.40
SMTM1632	CR1632	23.2	16.9	16.0	13.25	4.0	3.2	3.0	1.2	20.05	1.0	0.70
SMTM2032	CR2032	30.7	21.0	20.0	16.00	4.0	5.1	4.7	2.4	26.00	1.0	0.90

Battery holders

Surface mounting clip (SMTU-C)

Features

- Safety clip for coin cell retention
- Easy and fast replacement of the battery
- Designed for automatic «pick & place» mounting
- Clear separation of connections
- Protection against short circuits
- Protection against inverse polarity (polarized)
- Protection against leak currents
- Robust design
- Suitable for reflow soldering

Specifications

- Holder material: heat-resistant, glass fiber filled liquid crystal polymer (LCP)
- Flammability rating UL 94 V-0
- Battery contacts: spring stainless steel AISI 301, nickel-plated. Solder area tin-plated throughout, min. thickness 5 μm .
- Contact resistance between contacts and the cell is less than 100 m Ω (measured through AC 1 kHz; depending on the case material of the cell).
-  UL recognition, file E218732
- Temperature range: -40/+85 °C

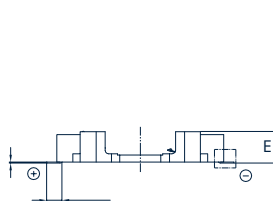

Side view

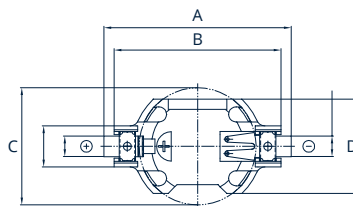

Top view

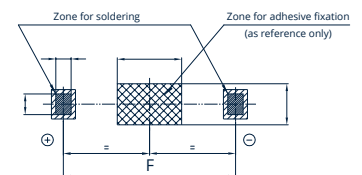

Layout top view

Maximum dimensions [mm]

RENATA part name	For use with RENATA cell	A	B	C	D	E	F	Weight [g]
SMTU1632-C	CR1632	27.7	24.3	16.0	14.5	5.4	25.1	0.80
SMTU2032-C	CR2032	32.0	28.5	20.0	16.1	5.4	29.4	0.95
SMTU2430-C	CR2430	36.4	33.0	24.5	16.1	4.9	33.8	1.05

Battery holders

Through-hole mounting (HU) – Horizontal

Features

- Easy and fast replacement of the battery
- Designed for automatic «pick & place» mounting
- Safe retention of coin cell
- Automated battery mounting possible
- Clear separation of connections
- Protection against short-circuits
- Protection against inverse polarity (polarized)
- Protection against leak currents
- Robust design
- Suitable for wave-soldering

Specifications

- Holder material: heat-resistant, glass fiber filled liquid crystal polymer (LCP)
- Flammability rating UL 94 V-0
- Battery contacts: spring stainless steel AISI 301, nickel-plated. Solder area tin-plated throughout, min. thickness 5 µm.
-  UL recognition, file E218732
- Temperature range: -40/+85 °C

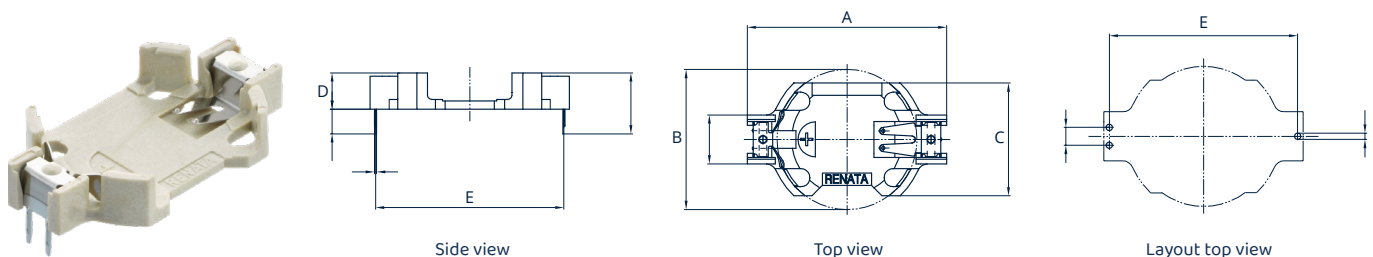

RENATA part name	For use with RENATA cell	A	B	C	D	E	Weight [g]
HU357-LF	357	19.9	11.6	12.0	7.4	18.65	0.84
HU1225-LF	CR1225	20.3	12.5	12.7	4.6	19.10	0.70
HU1632-LF	CR1632	24.3	16.0	14.5	5.2	23.00	0.80
HU2032-LF	CR2032	28.5	20.0	16.1	5.2	27.20	0.95
HU2430-LF	CR2430	33.0	24.5	16.1	4.7	31.70	1.05
HU2450N-LF	CR2450N	33.0	24.5	16.1	7.3	31.75	1.45
HU2477N-LF	CR2477N	33.0	24.5	16.1	10.1	31.80	1.65

Battery holders

Through-hole mounting (VBH) – Vertical

Features

- Small PCB foot print
- Easy and fast replacement of the battery
- Safe retention of coin cell
- Protection against short-circuits
- Protection against inverse polarity (polarized)
- Protection against leak currents
- Robust design
- Suitable for wave and reflow soldering

Specifications

- Holder material: high performance polyamide
- Flammability rating UL 94V-0
- Battery contacts: spring stainless steel AISI 301, nickel-plated.
-  UL recognition, file E218732
- Temperature range: -40/+85 °C

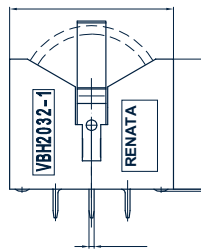
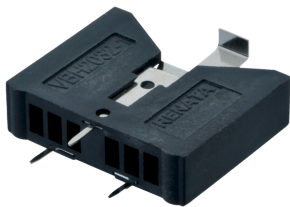

Front view from
(-) pole side

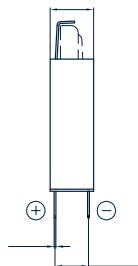

Side view

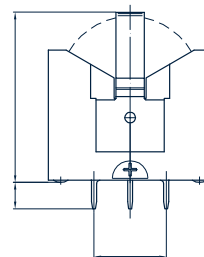

Front view from
(+) pole side

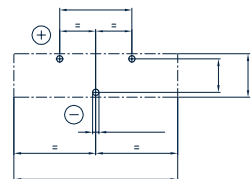

Layout top view

RENATA part name	For use with RENATA cell	Weight [g]
VBH2032-1	CR2032	1.86

Battery holders

Through-hole mounting with positioning pins (NH/NL)

Features

- Easy and fast replacement of the battery
- Snap-on fixing for coin cells
- Safe retention of coin cell
- Clear separation of connections
- Protection against short-circuits
- Protection against inverse polarity
- Protection against leak currents
- Robust design
- Easy and safe PCB mounting due to additional positioning pins
- Suitable for wave-soldering

Specifications

- Holder material: polyamide 66.
- Flammability rating UL 94 V-0
- Battery contacts: Nickel 99.6 DIN 17740
- Contact resistance between contacts and the cell is less than 100 mΩ (measured through AC 1kHz)
- Solder and positioning pins tin-plated, min. thickness 5 μm.
-  UL recognition, file E218732
- Operating temperature range: -40/+85 °C

NH5077-LF Vertical version

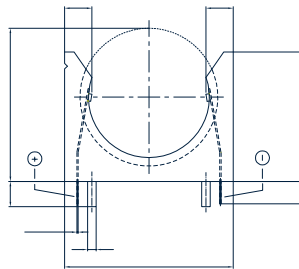

Front view



Side view

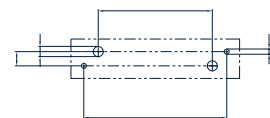

Layout top view

NL5077-LF Horizontal version

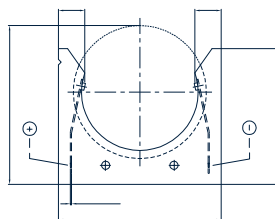

Front view

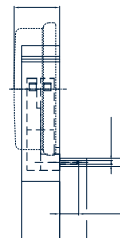

Side view

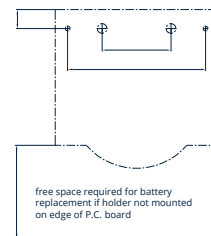

Layout top view

RENATA part name	For use with RENATA cell	Weight [g]
NH5077-LF	CR2450, CR2477	2.4
NL5077-LF	CR2450, CR2477	2.9

Battery holders

Packaging options

Battery holders can be supplied in different packaging formats.

Industrial bulk packaging

Packaging Code: IB

As a standard, the industrial bulk for battery holders is not packed in trays. In case the manufacturer requires it, it is also possible to pack the holders on a tray. The number of battery holders per tray depends on the respective model. So does the number of trays per shrink pack.



Tape & Reel packaging

Packaging Code: TR



For SMT-battery holders there is a Tape & Reel packaging solution available. Tape & Reel packaging is ideal for high speed, automated manufacturing lines. The number of battery holders per reel depends on the respective model.

Quantity per reel

RENATA part name	Quantity per Reel
SMTU1225-LF TR	750 pieces
SMTU1632-LF TR	520 pieces
SMTU2032-LF TR	485 pieces
SMTU2430-LF TR	490 pieces
SMTU2450N-LF TR	350 pieces
SMTU2477N-LF TR	250 pieces
SM2x2016-LF TR	485 pieces

Battery holders

Packaging options

Dimensions of antistatic carrier tapes

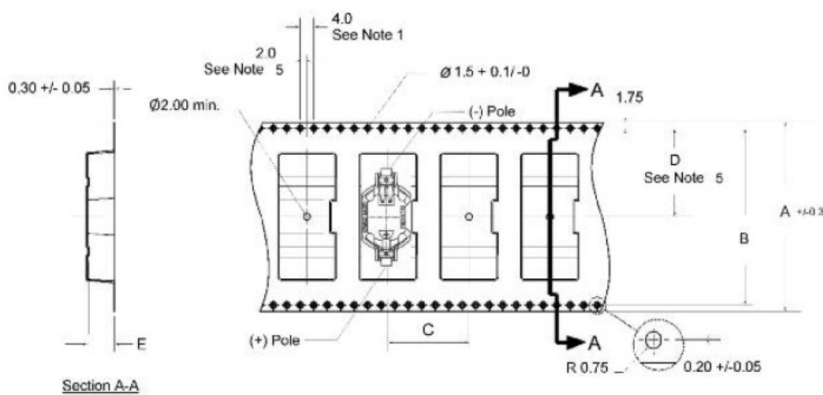

1. 10 sprocket hole pitch cumulative tolerance +/-0.02
2. Camber not to exceed 1 mm in 100 mm.
3. Material: Black conductive Advantek polystyrene.
4. E measured from a plane on the inside bottom of the pocket to the top surface of the carrier.
5. Pocket position relative to sprocket hole measured as true position of pocket, not pocket hole.

RENATA part name	Dimensions [mm]				
	A	B	C	D	E
SMTU1225-LF TR	44.0	40.4	16.0	20.2	5.7
SMTU1632-LF TR	44.0	40.4	20.0	20.2	6.1
SMTU2032-LF TR	44.0	40.4	24.0	20.2	6.0
SMTU2430-LF TR	56.0	52.4	24.0	26.2	5.7
SMTU2450N-LFTR	56.0	52.4	24.0	26.2	8.2
SMTU2477N-LF TR	56.0	52.4	24.0	26.2	10.8
SM2x2016-LF TR	44.0	40.4	24.0	20.2	6.0

Dimensions of antistatic packaging reels

RENATA part name	Dimensions [mm] W max.
SMTU1225-LF TR	50 ±1.0
SMTU1632-LF TR	50 ±1.0
SMTU2032-LF TR	50 ±1.0
SMTU2430-LF TR	50 ±1.0
SMTU2450N-LF TR	62 ±1.0
SMTU2477N-LF TR	62 ±1.0
SM2x2016-LF TR	50 ±1.0

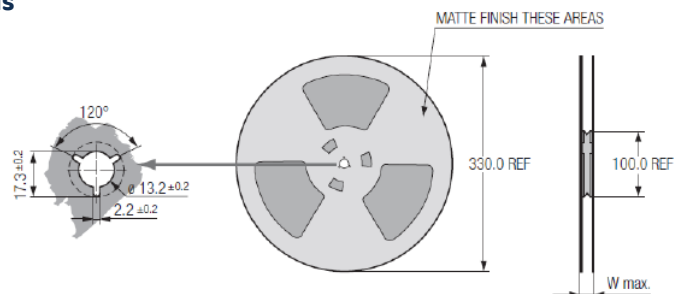

All packaging materials comply with relevant EIA, EIAJ and IEC specifications.

Thin film lithium metal battery

Introduction

High quality batteries are extremely important in today's and tomorrow's connected world. Wearable technologies and smart medical devices are remarkable market segments witnessing significant growth and they can only deliver performance when equipped with the right power supply. Small in size, the Thin film battery is ideal to create smaller electronic devices such as smart cards, smart textiles, price tags, smart packaging labels, smart wristbands, sensors, RFID, etc.

Advantages

- Nominal voltage of 3 V
- Flexible, ideal for patches and curved designs
- Ultra-Thin: 0.45 mm
- Environmental-friendly

General characteristics

- Self-discharge: less than 5% per year at 23 °C
- High pulse capability
- Wide operating temperature range: -40 °C to 60 °C
- Stainless-Steel tabs – Optional: Tin over Nickel plated tabs



Dimension and weight

Model	Thickness	Max. Dimension [mm]			Approx. Weight [g]
		Width	Length		
CP042350	0.45	23.30	50.30		0.86

Electrical characteristics

Model	Nominal capacity [mAh]	Max. Continuous discharge current [mA]	Max. Non-continuous discharge current [mA]	Operating Temperature [°C]
CP042350	28	0.625	12.5	-40/+60

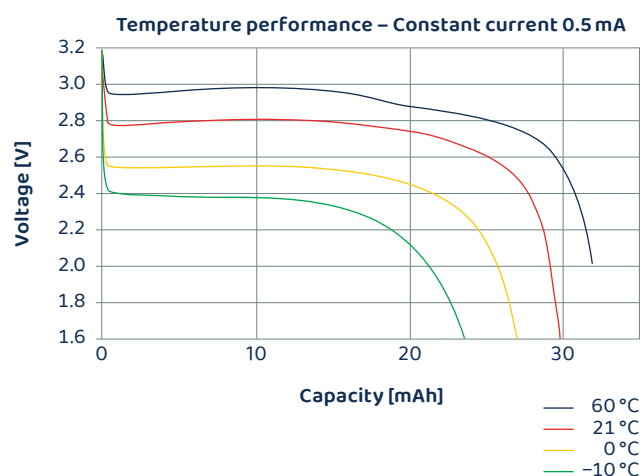
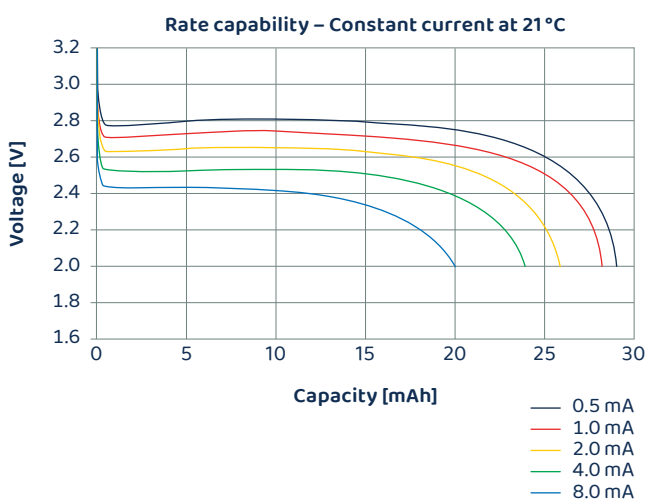

Rechargeable lithium-ion coin cells

Introduction

In the future, portable electronic devices will increasingly use rechargeable batteries instead of primary batteries. Committed to provide the best battery solutions, RENATA developed the new product line of rechargeable Lithium-ion coin cells.

Advantages

- Nominal voltage of 3.2 V (IFR – LiFePO_4) and 3.7 V (ICR – LiCoO_2)
- Able to charge up to 1.0 C (constant current) for ICR and IFR
- Able to discharge up to 2.0 C for ICR (non-continuous current) and up to 3.0 C (non-continuous current)
- Products with a wide range of nominal capacity (16 to 100 mAh)
- Mechanically robust designs, resilient against high and low temperatures, and mechanical stress.

General characteristics

- Standard charging current (continuous) of 0.5 C for ICR and IFR
- Stacked electrodes that deliver full capacity for a longer service life
- Cycle life at room temperature: >80% of min. capacity after 500 cycles (ICR) and 1000 cycles (IFR)
- Wide operating temperature range: $-20\text{ }^\circ\text{C}$ to $60\text{ }^\circ\text{C}$

Rechargeable lithium-ion polymer batteries

Introduction

RENATA offers a standard line of Lithium-ion Polymer batteries.

Advantages

- Nominal voltage of 3.7–3.85 V
- Polymeric electrolyte for higher safety
- Products with a wide range of sizes and capacity (24 to 2700 mAh)
- Cycle life at room temperature: >80% of min. capacity after 500 cycles
- Contact with wires, tabs and connectors
- Safety circuit integrated in most battery models (wire and connector contacts)

General characteristics

- Max. Charging current (constant current): 1.0 C
- Max. Discharge current: 1.0 C (constant current), 2.0 C (non-continuous current)
- Wide operating temperature range: -20 °C to 60 °C
- Self-discharge: <2% per month at room temperature

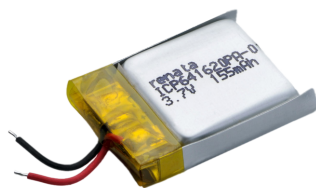

With safety circuit + Wire contact

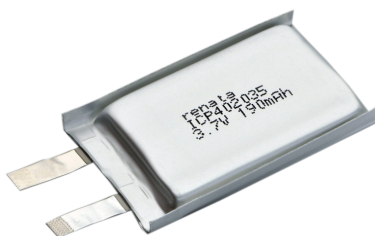

No safety circuit + Tab contact



With safety circuit + Connector

Rechargeable lithium-ion polymer batteries

Electrical characteristics, dimensions and weight

Model	Nominal capacity [mAh]	Max. Dimensions [mm]			Weight [g]	Safety circuit	Contact
		Thickness	Width	Length			
ICP241019	25	2.40	11.20	19.30	1.3	No	Tabs
ICP341018PM	35	3.70	10.20	19.50	1.7	Yes	Wire
ICP331319PM	50	3.75	12.60	20.30	2.0	Yes	Wire
ICP281029HPG ***	68	3.30	10.20	30.50	2.4	No	Tabs
ICP390831PR	80	4.30	8.70	33.00	2.8	Yes	Wire
ICP501022UPM	80	5.50	10.00	24.00	2.6	Yes	Wire
ICP641414PE	95	6.80	14.90	16.80	2.7	Yes	Wire
ICP501421PS	115	5.20	14.10	22.50	3.1	Yes	Wire
ICP651321PA-01	120	7.00	13.20	23.50	3.3	Yes	Wire
ICP401230UPR	130	4.50	12.70	31.00	3.5	Yes	Wire
ICP521522PS **	130	5.70	15.50	23.50	3.4	Yes	Connector
ICP501230PS-03	135	5.40	12.50	31.50	3.6	Yes	Wire
ICP581323PA-01	145	6.20	13.20	25.00	3.7	Yes	Wire
ICP402025PC-01	155	4.30	20.50	27.50	4.0	Yes	Connector
ICP641620PA-01	165	6.90	16.20	21.50	3.9	Yes	Wire
ICP501233PA-02	175	5.30	12.00	35.00	4.2	Yes	Wire
ICP402035	195	4.40	20.00	35.00	4.8	No	Tab
ICP401835TPRT **	215	4.40	18.20	37.00	5.4	Yes	Wire
ICP621333PA-01	240	6.70	13.00	35.00	5.5	Yes	Wire
ICP521630PM-01	250	5.70	17.00	31.50	5.4	Yes	Wire
ICP621333HPMT ** ***	270	6.80	13.00	35.00	5.6	Yes	Wire
ICP403029PL-02	325	4.40	31.00	31.00	7.0	Yes	Wire
ICP422339PR	340	4.60	23.70	40.50	7.3	Yes	Connector
ICP582035PR-01	340	6.40	20.50	37.00	7.3	Yes	Wire
ICP602823PA-01	350	6.40	28.00	25.50	7.3	Yes	Wire
ICP402050PR	420	4.50	20.70	52.50	8.8	Yes	Wire
ICP582930PR-01	450	6.20	29.50	32.00	9.1	Yes	Wire
ICP303450PA-02	510	3.60	34.50	52.00	10.8	Yes	Wire
ICP632136HPST ** ***	520	6.95	21.50	39.50	9.6	Yes	Wire
ICP682828HPMT ** ***	560	7.50	28.00	30.00	10.3	Yes	Wire
ICP622540PMT	600	6.50	25.70	42.50	11.0	Yes	Wire
ICP543759PMT	1320	5.95	37.50	61.00	26.0	Yes	Wire
ICP606168PRT	2800	6.30	62.00	71.00	70.0	Yes	Wire

** NTC Temp Sensor built in

*** 3.85 V model

Rechargeable lithium-ion polymer batteries

ICP651321PA-01 (rated 120 mAh)

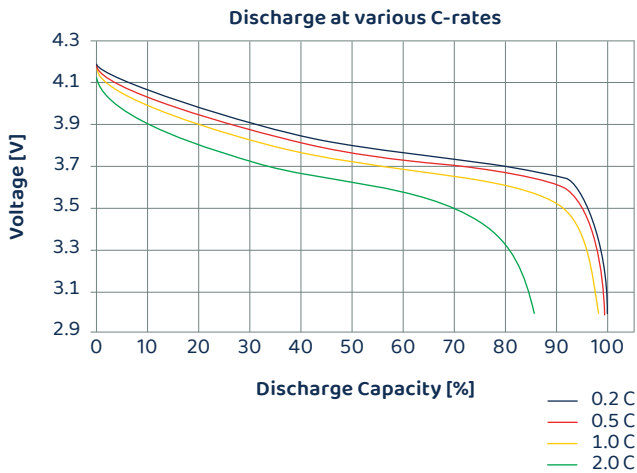

Charge: 0.5 C to 4.2 V & 5% cut-off;
 Discharge at various C-rates at CC to 3.0 V

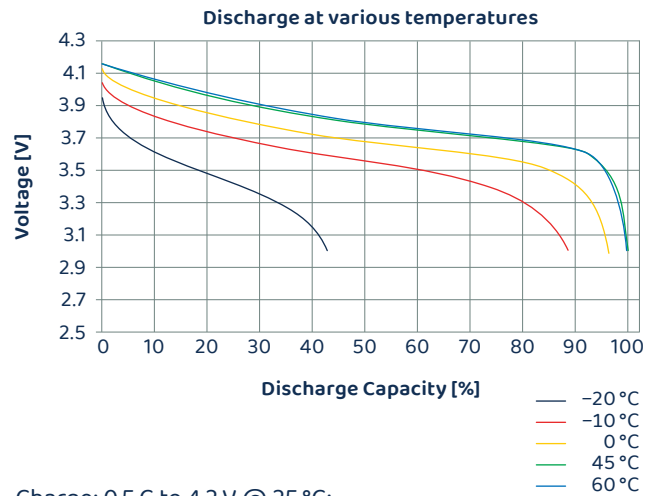

Charge: 0.5 C to 4.2 V @ 25 °C;
 Discharge: 0.5 C to 3.0 V

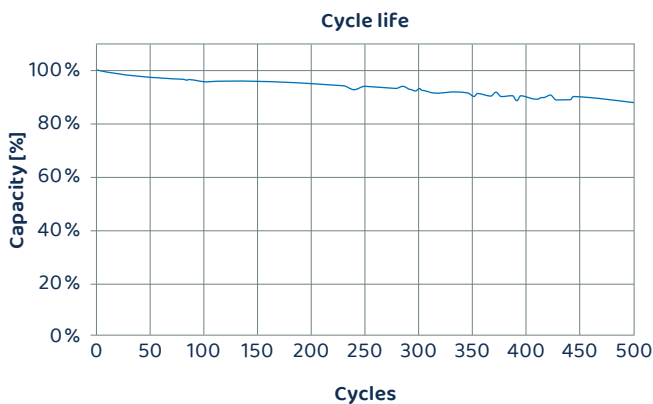

Charge: 0.5 C to 4.2 V & 5% cut-off
 Discharge: 0.5 C to 3.0 V

Chemistry and construction

Chemistry of RENATA silver oxide coin cells

RENATA silver oxide coin cells use an aqueous electrolyte containing either sodium hydroxide (NaOH – for Low drain) or potassium hydroxide (KOH – for High drain). The anode material is a paste based on zinc metal, and the cathode material consists of a mixture of silver oxide and other specific components.

The cell reactions for this electrochemical system are:



The silver oxide is reduced at the cathode to silver, while the zinc is oxidized at the anode.

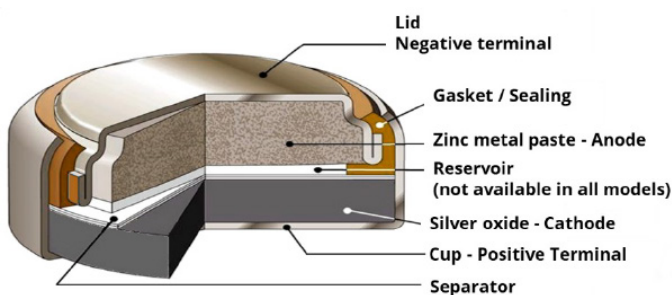

Chemistry of RENATA Li/MnO₂ coin cells

RENATA CR lithium coin cells use a non-aqueous, aprotic organic electrolyte containing lithium perchlorate. The proprietary formulation of the active cathode material consists of a heat-treated mixture of electrolytic MnO₂ and other specific components.

The cell reactions for this electrochemical system are:



Manganese dioxide is reduced from the tetravalent to the trivalent state by lithium. The separator system in RENATA coin cells is especially designed to ensure the best performance in terms of mechanical strength, ion permeability over a wide temperature range (–40 to +80 °C) and a low self-discharge rate.

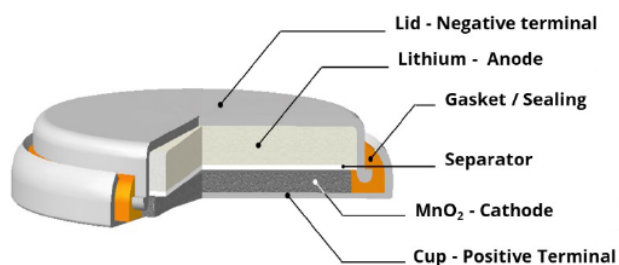

Electrical & temperature performance

Pulse discharge characteristics

RENATA Lithium batteries have excellent pulse load characteristics, for example for the transmission of radio signals by remote controls.

The following diagrams show the voltage characteristics of an electronic key pulse test, with a load of 10 mA (5 seconds On, 55 seconds Off, 24 h a day with a cut-off voltage of 1.8 V) at three different temperatures (-20 °C, 0 °C and room temperature 23 °C) on a CR2032.MFR RENATA battery.

Please contact RENATA for further details.

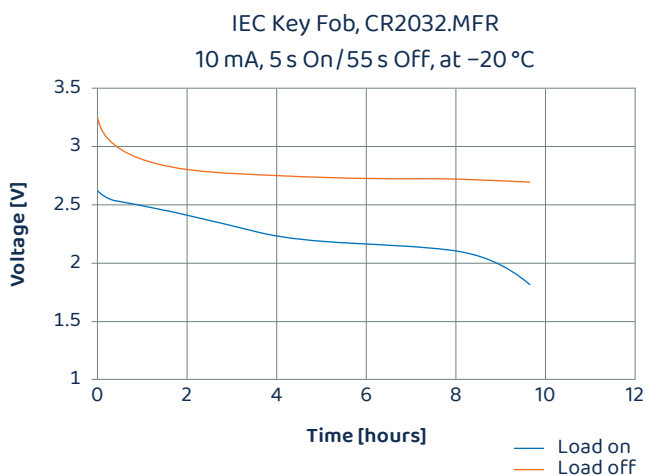
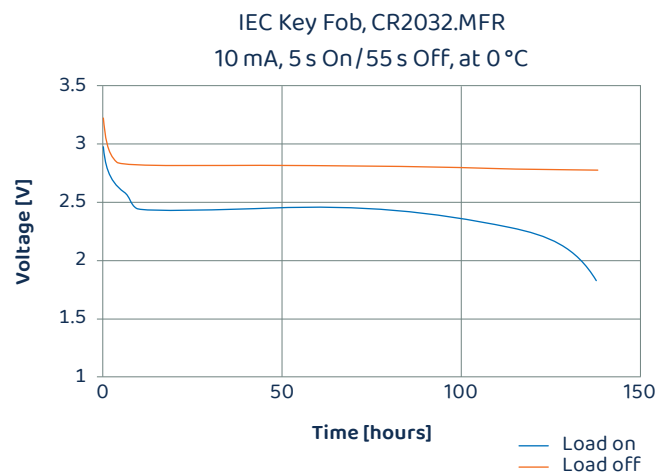
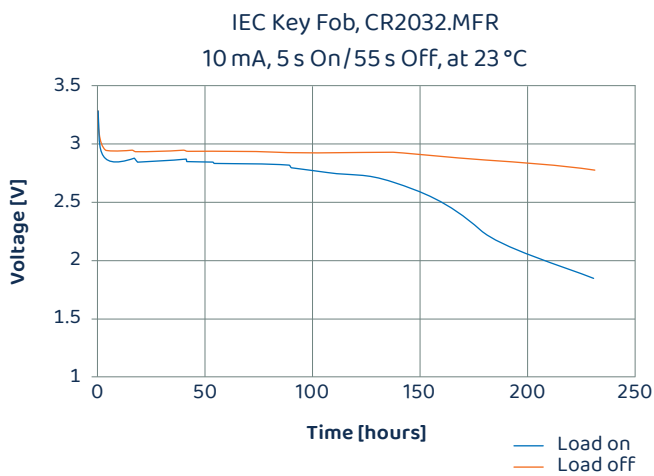

Electrical & temperature performance

Inverse current

Lithium primary batteries are not rechargeable. Therefore, if there is a possibility of electric current flowing from the main power source to the battery, the circuit must include two suitable blocking diodes in series or one blocking diode and one protective resistor in series (refer to drawing in chapter SAFETY GUIDELINES). Use a silicon diode of small inverse current to prevent charging. **The total amount of recharge energy due to leakage by the blocking diodes should not exceed 1% of the battery's nominal capacity during its total service life. A higher input of recharge energy may harm the battery or reduce its performance.**

Example: A CR2450N battery with a nominal capacity of 540 mAh is expected to supply power for 5 years. The amount of tolerable re-charge capacity is 5.4 mAh, corresponding to current of 0.123 μ A for the total service life¹. Consequently, a blocking diode with an inverse current not greater than 0.1 μ A should be selected. Please note that the inverse current of blocking diodes varies with temperature.

¹ 540 mAh * 1% = 5.4 mAh

5.4 mAh / (5 years * 365 days * 24 h) = 0.123 μ A

Short circuits

When lithium batteries are short-circuited, it takes time for the battery voltage to recover, even in case of slight short-circuits. If electrical characteristics are measured while the battery is recovering, the battery may appear to be defective, but is not. Short-circuiting leads to deterioration of the cell capacity. Short-circuiting of batteries must therefore be avoided, except for wave or dip soldering. Use an instrument with a high input impedance (minimum 10 M Ω) for measuring open circuit voltage.

Superior environmental resistance

The combination of RENATA's sealing system and the use of organic electrolytes with low creeping tendency ensure the excellent leakage resistance of our batteries. Each production lot is subjected to a quality assurance program under difficult environmental conditions (high temperature storage, high temperature/high humidity storage, temperature cycling, etc.). RENATA batteries can be operated in any physical position.

Passivation phenomena

Lithium is among the most reactive elements. It easily reacts with a number of substances, including water and air. Because of this high reactivity, the commercial exploitation of lithium based electrochemical systems has been for long time hindered by the reaction between lithium and several electrolytes. Only in the 80s, suitable electrolytes were developed, based on aprotic organic solvents. The reason for the stability of electrolytes based on organic solvents lies in the passivation layer that is built at the lithium surface.

This protective layer (also called SEI, Solid-Electrolyte-Interphase) stops the reaction between electrolyte and lithium and due to its mechanical characteristics, ensures good stability for long times. Therefore, the formation of a layer of right properties is a key element for the achievement of long-term storage properties.

A number of factors, including the formulation of the electrolyte and the production conditions, influences the formation of the SEI layer. In addition, a particular step of the manufacturing process plays a decisive role in the formation of the right SEI layer: the pre-discharge step (i.e. a discharge limited to some percentage of the theoretical capacity of the cell) of 100% of the produced cells. By carefully controlling the pre-discharge parameters, a passivation layer of optimized physical-chemical characteristics is created at the interphase lithium-electrolyte.

Unlike other lithium-based battery technologies, a passivation layer of growing thickness does not characterize the CR (Li/MnO₂) system after long-term ageing of the cells or after short exposures at high temperature. The SEI layer of CR cells built at the beginning does not change significantly even after years of storage at controlled temperature (see related section in this chapter – FAQ about recommended storage conditions). In other lithium systems, instead, a growth of the layer with ageing time, is observed, turning out in a reduced pulse capability (the well-known «voltage delay effect, especially observed for liquid cathode systems when trying to request high pulses after long time storage at room temperature, or after short periods at high temperature). For these other lithium systems, it is necessary to apply a continuous load of low current to minimize passivation phenomena; on the contrary, for CR systems this precaution is not necessary.

Soldering

Hand soldering

Never solder directly to the cell surface. Use cells with tabs only (see related section of our Products Line). Do not allow the soldering iron to get directly in contact with the battery body. Do not apply heat any longer than necessary to achieve a safe solder connection (max. 350 °C for 5 s in the soldering area of the tab).

Wave soldering

During passage of the battery terminals through the solder wave, the battery is short-circuited. As this usually takes less than 5 seconds, the loss of capacity is negligible. Subsequent to a short circuit, the battery voltage will recover to a value above 2.5 V almost immediately. Full recovery to the initial voltage may take hours or even days. Please note this effect in case electrical characteristics are measured while the battery voltage is recovering. The battery may appear to be defective, but it is not. Temperature at the battery needs to be controlled below 85 °C.

No reflow soldering with batteries

Never use reflow soldering on batteries! Lithium batteries are not suitable for reflow soldering processes. The high temperatures required for this soldering method would deform the gasket, causing electrolyte leakage, deterioration of the battery performance and possible rupture or ignition.

Reflow soldering of SMTU holders

If assembly by reflow soldering is requested, it is possible to solder a RENATA battery holder of the SMTU series but place the battery into the holder after the soldering process. The peak temperature of the reflow soldering profile is recommended to not be above 270 °C for 40 s (245 °C for another 40 s).

Frequently Asked Questions (FAQ)

General electrical performance

Which values of open circuit voltage do lithium cells typically show?

The CR-type coin cells, based on the lithium/manganese dioxide electrochemical system, have a nominal voltage of 3 V. In practice, a fresh lithium cell will typically show an OCV (Open Circuit Voltage) between 3.10–3.40 V. This range of values is intended for measurements performed at room temperature; in fact, the OCV values depend on the temperature of the measurement.

After storage periods the cells may also show values outside this range, due to ageing effects (see the recommended storage conditions for lithium coin cells, also reported in this document).

What is the internal resistance of a cell? How does it affect the performance of the cell?

From an electrical point of view, a cell is a combination of an energy source and a resistance. The internal resistance (R_i) is a key parameter for a cell, as it determines its high power capability (i.e. its ability of delivering its energy in a short time). The internal resistance reduces the useful voltage in applications and leads to internal heat, thus loss of power, which increases with the square of the current.

The internal resistance of a lithium cell is a sum of both ohmic contributions and of resistive contributions coming from electrochemical phenomena taking place during the discharge of the cell. By accurate selection and quality control of materials, RENATA manufacturing process minimizes the resistive factors contributing to the internal resistance of the lithium cells.

As the internal resistance includes a number of resistive contributions coming from electrochemical phenomena, each of them being characterized by a time constant, the value of internal resistance is depending from the measuring method and conditions. A simple and inexpensive method for measuring the R_i is to apply a resistive load (R_1) to the cell and to measure the value of the cell voltage under load (CCV, Closed Circuit Voltage). The internal resistance is calculated as: $R_i = (OCV - CCV) \times R_1 / CCV$.

Does the internal resistance change with time, or during the cell discharge?

There is a limited increase of the internal resistance of a primary cell during its service-life. In the case of lithium coin cells, the normal increase during the cell discharge is due both to ohmic factors and to electrochemical phenomena taking place at the lithium anode (growing of interface films between lithium metal and electrolyte solution).

The increase of the overall internal resistance with increasing discharge level is reported in the figure below.

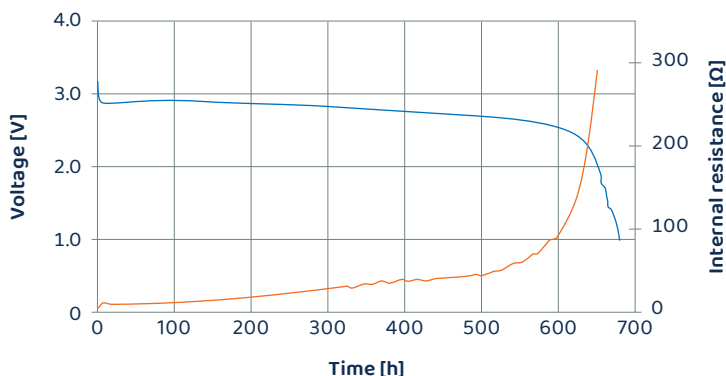

Figure: Characteristic curve of a CR2450N cell. Discharge load: $R_1 = 3.32 \text{ k}\Omega$. Measurement of internal resistance during discharge: by applying the load $R_2 = 150 \Omega$ for 1 s, every 3 hrs.

¹ This curve is intended as typical data and not as cell specification.

Frequently Asked Questions (FAQ)

General electrical performance

The ageing of the cells at normal conditions (i.e. room temperature, max. 40% of relative humidity) will also lead to the increase of the internal resistance, due to normal ageing phenomena taking place at the electrodes. However, of limited extent, these types of increases of the internal resistance are normally to be expected and must be taken into account, when designing a new application.

Exposing the cells to elevated temperatures, then, can lead to further growth of the passivation films at the anode, with an additional increase of internal resistance. Furthermore, increasing the temperature above 70 °C can cause the internal resistance to abnormally increase (because of electrolyte leakages and degradation phenomena). Abuse conditions such as discharge at elevated currents and short-circuit can also increase the internal resistance abnormally, because of the deterioration of cell internal components.

Which is the voltage drop of the lithium cell during current pulse?

The voltage drop during a current pulse (ΔV) is the difference between the cell voltage just before applying the pulse (Voltage-high, V_1) and the cell voltage during the pulse (Voltage-low, V_2): $\Delta V = V_1 - V_2$

It is also expressed by the formula: $\Delta V = R_i \times I_{peak}$, where the internal resistance R_i depends on the cell type and dimensions.

In addition, the value of R_i depends on the temperature and on the discharge level of the cell (see related section about internal resistance). Therefore, the voltage drop of the cell will be strongly affected by the temperature and by the cell's discharge level.

From the above reported formula, it also follows that the voltage drop strictly depends on the applied pulse itself-particularly on the value of the pulse-current (I_{peak}). The voltage drop is also affected by the other parameters that define a pulse-load. These parameters are the pulse duration (i.e. the length of the applied pulse current I_{peak}), the pulse period (i.e. the time between two subsequent pulses), the frequency with which the pulse trains occur (i.e. how often the pulse trains are applied to the battery) and – eventually – the basis-current (i.e. the current applied between two pulse trains). The last three pulse parameters affect the voltage drop during pulse, because their settings affect the value of the cell voltage just before applying the pulse (V_1).

An example of voltage and internal resistance behavior during a pulse discharge is reported below.

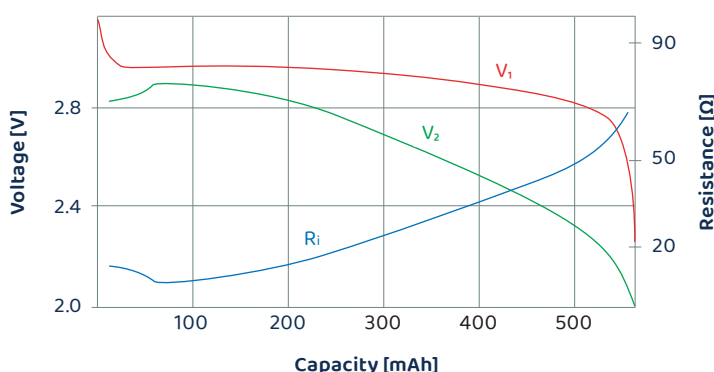

Figure: Pulse-current discharge characteristics¹ of the CR2450N cell. CR2450N Pulse intensity 10 mA, pulse width 50 ms, period 1 s. Cut-off voltage: 2.0 V

¹ This curve is intended as typical data and not as cell specification.

Frequently Asked Questions (FAQ)

General electrical performance

What is the maximum pulse current the lithium coin cells can handle?

There are no specified limits for the peak current value in pulse applications. Instead, current limits can be defined by means of a series of factors and practical considerations related to the electrical application, like the load profile, the cut-off voltage and the targeted service-life of the cell in the application. Electrical applications are normally regulated by a voltage threshold (cut-off voltage), under which the applications miss the required electric power to work and therefore will shut down. The cell is the energy/voltage source in the application; when the voltage during a pulse is lower than the cut-off voltage, the application will shut down. A proper design of the electrical application in terms of electrical load and cut-off voltage, combined with the choice of the cell of right energy and power characteristics, are of paramount importance in order to achieve the targeted service-life of the application. The mutual relation that links application characteristics, cell performances and targeted application services is illustrated below.

Consult RENATA experts in order to calculate and select the cell with the right characteristics for your application and achieve your goal!

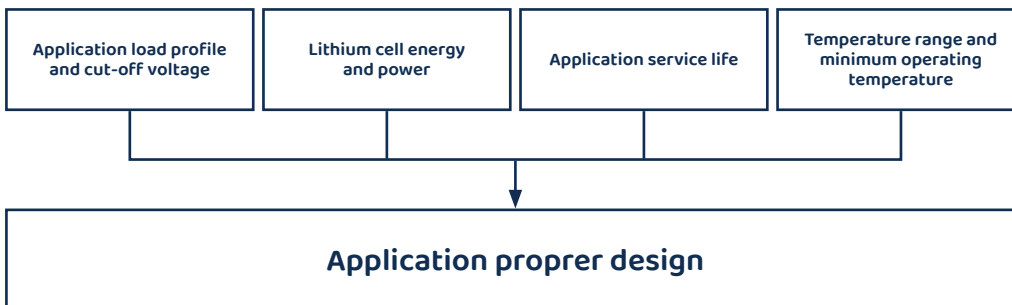

What is the shortest time period for testing the behavior of batteries?

It is common to perform accelerated tests to prove the lifetime of the battery in the application or to test the performance of different batteries.

According to IEC 60086-1 it is recommended to discharge the battery for a period of approx. 30 days. With the standard discharge current one achieves 100% of the guaranteed capacity within these 30 days.

However, also expedited test are possible when the resulting capacity decrease is taken into consideration.

The limit of the average discharge current is the max. Continuous discharge current. It is not recommended to perform tests with currents beyond this limit because the results may not be typical or they could be misleading. Li/MnO₂ batteries are designed to supply low currents for several years. Therefore, test results are rather random when discharging the batteries in very short time periods with high currents.

Frequently Asked Questions (FAQ)

Influence of temperature on electrical performance

Ambient temperatures over the given max. operating temperature may be possible for a short period of time. Please ask RENATA experts for advice on this matter.

Has high temperature any detrimental effect on the cell performance?

Increasing temperature to values above room temperature will increase the rate of self-discharge, reducing the available cell capacity – thus shortening both the service-life and the shelf-life. The self-discharge of a cell is due to parasitic reactions taking place at the electrodes, consuming the electroactive material. As for every reaction, the rate of these processes is function of temperature. A simple «rule of thumb» to determine the self-discharge at a given temperature is the following: the rate of self-discharge increases of a factor 2 for every 10 degrees Celsius of temperature increase from room temperature (20 °C). Given that at room temperature the rate of self-discharge of lithium coin cells is 1% of capacity loss per year, at 40 °C (for example) the self-discharge rate will be: $1\% \times 2^{(40-20)/10} = 1\% \times 2^2 = 4\%$ of capacity loss/year.

In addition to self-discharge considerations, the maximum storing and operating temperature for the lithium coin cells must not exceed the given max. operating temperature, in order to avoid any electrolyte leakages, leading to reductions of cell functionality.

Characteristics

Shelf life (temperature/time)

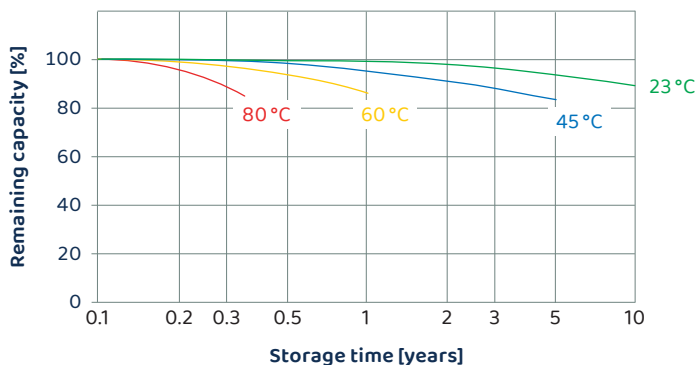

Frequently Asked Questions (FAQ)

Influence of temperature on electrical performance

Storage characteristics (CR2430)

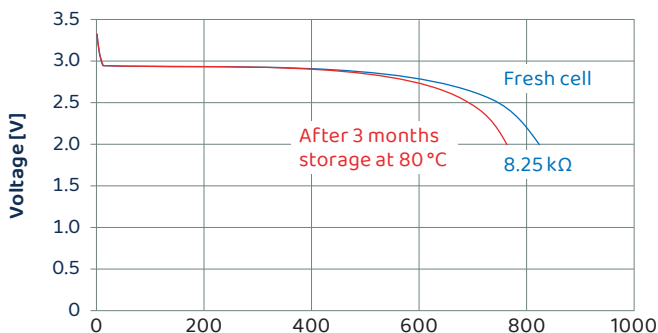
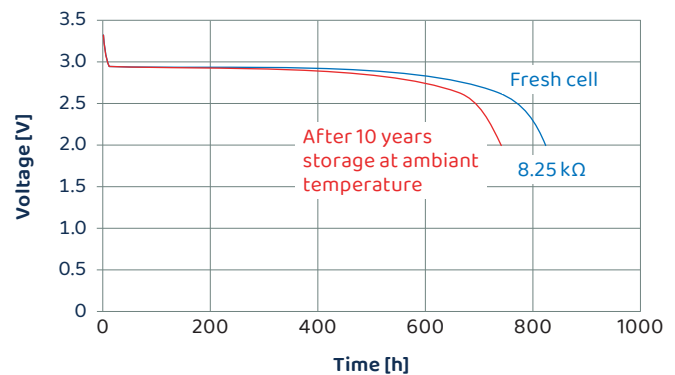
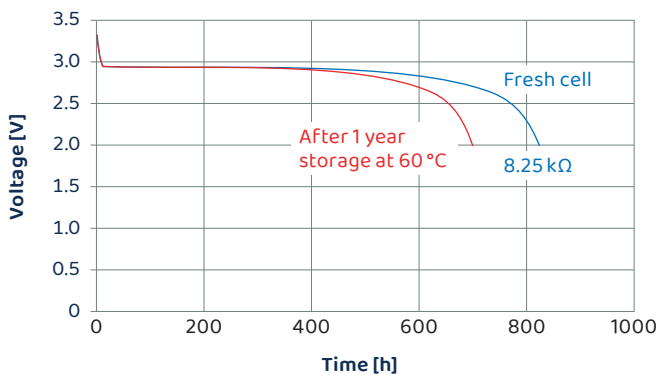

Has low temperature any detrimental effect on the cell performance?

The performance of a cell at low temperature is reduced because of the decreased conductivity of the electrolyte, which leads to an increase of internal resistance. Hence, the ability of the cell to deliver high power is also reduced. Especially when designing an application with high power demand (high current consumption, like pulse-loads), this factor must be carefully taken into account.

Influence of storage/ageing on electrical performance

Which are the recommended storage conditions for lithium coin cells?

The normal storage of lithium coin cells is made at temperature between +10 °C and +25 °C, never exceeding +30 °C (also according to IEC 60086-1). In this way, the maximum shelf-life (i.e. max. retention of cell performances after storage periods) of lithium coin cells is achieved.

Storage temperatures above room temperature will increase the rate of self-discharge, reducing the available capacity of the cell. Humidity above 95 % R.H. and below 40 % R.H. should also be avoided for sustained periods, as these extremes are detrimental to batteries.

Storing the cells at low temperature is also suggested, but attention must be paid when transferring the cells to warmer environments, because of the possibility of having water condensing on to the cells (risk of short-circuits).

Frequently Asked Questions (FAQ)

Influence of contact material

Which contact materials are recommended?

Recommended contact materials:

- Gold plating – provides the most reliable metal-to-metal contact under all environmental conditions.
- Solid nickel – provides excellent resistance to environmental corrosion.
- Nickel-clad stainless steel – performs almost as well as solid nickel.
- Nickel plated stainless steel – also a reliable metal-to-metal contact (also used for RENATA's battery holders SMTU/HU series).
- Inconel alloy – provides good electrical conductivity and corrosion resistance.

Compared to stainless steel, nickel plated contacts are easier to solder.

Which contact force and design ensure best electrical performance and reliability?

The contact force of the contacts should be between 2 and 10N (ca. 200 to 1000 gf).

Contact design: It is important that contacts apply sufficient pressure to hold the battery firmly in place and prevent electrical disconnections (even under shock conditions). Contacts must be able to resist permanent set. Furthermore, two contact points guarantee more reliability than only one.

Can batteries undergo washing processes?

Please use non-conductive cleaning solutions for the PCB washing process. In conductive solutions, the batteries are short-circuited, causing discharge, voltage drop and possibly deterioration of the cell performance. Use cleaning solutions that do not attack the polypropylene cell gasket.

Are RENATA lithium cells certified in terms of safety?

Underwriters Laboratories Inc., Northbrook/IL/USA, certifies the safety of RENATA cells, under the file number MH14002. See also: www.renata.com and the Safety Section in this Guide.

Technical consultancy service

Application design support

The world of electronic application does not cease to grow with impressive pace – every day new ideas and smart solutions are translated in powerful applications with innovative features.

When selecting a battery, the following technical factors have to consider:

- Current consumption of the device
- Pulse drain characteristics
- Voltage – minimum and maximum values
- Expected life time of the battery
- Environmental temperatures
- Mechanical and normative requirements/specification

Do not hesitate to get technical support directly from RENATA's engineering team to find the right battery for your particular application.

Contact data of RENATA's Technical Customer Support

For any technical question about RENATA Lithium coin cells, holders, standard tab configurations or customized solution, please address your inquiries to our engineering team:

RENATA SA

Technical Customer Support

4452 Itingen

Switzerland

Phone: +41 61 975 75 75

Fax: +41 61 975 75 99

Email: sales@renata.com

Application Worksheet

RENATA Application Worksheet is our key tool for offering the best technical consultancy service to the developers of new electronic devices. By gathering all useful information about load and temperature conditions of use, we deliver an ultimate feasibility evaluation and help selecting the right power source for a given application.

You can download a copy of the Application Worksheet from RENATA's website or just fill and send via fax the copy reported below.

Please, consider supplying the most detailed information will give the best accuracy to the battery assessment.

Application worksheet

Please submit the information according to the following selection guide and send the application worksheet back to your contact person.

Customer information

Company: _____
 Address: _____

 Contact Person: _____
 Telephone: _____

 Fax: _____
 E-Mail: _____

Electrical characteristics

Voltage: V max V Cut-off V
 Continuous Load: I max mA

In case of pulse-loads, please define pulse parameters. Submitting your own detailed pulse scheme and using your own pulse description is strongly encouraged for best clarity. Alternatively, you can use the following table of pulse parameters (defined according the scheme below):

Pulse parameters

	Pulse intensity [nA, µA, mA]*	Pulse width [ns, µs, ms, s min, h]*	Pulses per unit [s, min, h, day, month, year, lifetime]*
Pulse 1	*	*	*
Pulse 2	*	*	*
Pulse 3	*	*	*
Pulse 4	*	*	*
Pulse 5	*	*	*

*please select the corresponding unit

You can add further explanation /info about your pulse profile her:

Application worksheet

Temperature/Humidity

Please submit the temperature profiles to which your application will be typically exposed.

Temperature profile: °C max. °C min. °C mean
Humidity % RH max. % RH min % RH average

For a precise performance evaluation, please indicate exactly how long the application will be exposed to each of the following temperatures:

Days per year		Days per year	
<0°C	<input type="text"/>	50 °C	<input type="text"/>
0–20 °C	<input type="text"/>	55 °C	<input type="text"/>
20 °C	<input type="text"/>	60 °C	<input type="text"/>
25 °C	<input type="text"/>	65 °C	<input type="text"/>
30 °C	<input type="text"/>	70 °C	<input type="text"/>
35 °C	<input type="text"/>	75 °C	<input type="text"/>
40 °C	<input type="text"/>	80 °C	<input type="text"/>
45 °C	<input type="text"/>	85 °C	<input type="text"/>

Mounting mode

Mounting mode Plain cell with soldering tags Horizontal/ Vertical
 In combination with a battery holder
 Mounted on SMT board
 Mounted on through hole board

Operation requirements

Expected operating life: Years
Storage period: Years

Specific project information

New project Yes/ No
Project name
End customer
Qty. pre-series Pcs.
Qty. 1st series Pcs.
Qty. P.A. Pcs./year
Target price CHF/ USD/ EUR per 100 pcs.

Other information

Product description

Remarks

Safety guidelines

Handling instructions

Preventing quality problems

To prevent the batteries of being discharged please observe the following rules.

1. Do not place batteries on a conductive surface (anti-static work mat, packaging bag or form trays) as it can cause the battery to short.
2. Remove the batteries from the transport tray one at a time (do not throw batteries randomly by turning over trays)
3. Please make sure that batteries cannot touch each other while handling them.

Safety guidelines and precautions

Please observe the following warnings strictly. If misused, the batteries may explode or leak, causing injury or damage to the equipment.

1. Keep batteries out of the reach of children, especially those batteries fitting within the limits of the truncated cylinder defined in ISO/DP 8124/2.2 page 17. In case of ingestion of a cell or battery, the person involved should seek medical assistance.
2. Equipment intended for use by children should have battery compartments, which are tamperproof.
3. The circuits of equipment designed to use alternative power should be such as to eliminate the possibility of the battery being overcharged (see UL standard for diode use).
4. The batteries must be inserted into the equipment with the correct polarity (+ and -).
5. Do not attempt to revive used batteries by heating, charging or other means.
6. Do not dispose of batteries in fire. Do not dismantle batteries.
7. Replace all batteries of a set at the same time. Newly purchased batteries should not be mixed with partially exhausted ones. Batteries of different electrochemical systems, grades or brands should not be mixed. Failure to observe these precautions may result in some batteries in a set being driven beyond their normal exhaustion point and thus increase the possibility of leakage.
8. Avoid short-circuiting batteries.
9. Avoid directly soldering to batteries.
10. Do not expose batteries to high temperatures, moisture or direct sunlight.
11. When discarding batteries with solder tags, insulate the tags by wrapping them with insulating tape.
12. Improper welding can damage the internal components of batteries.

Correct replacement of a coin cell

RENATA's horizontal SMT and through-hole battery holders are made of heat resistant, glass fiber filled Liquid Crystal Polymer (LCP).

Despite the excellent characteristics of this holder material, it can happen that a holder is damaged when trying to replace a coin cell in an inappropriate manner.

In order to minimize such risk of damage, please replace the coin cell as demonstrated in the pictures below using an appropriate tool:

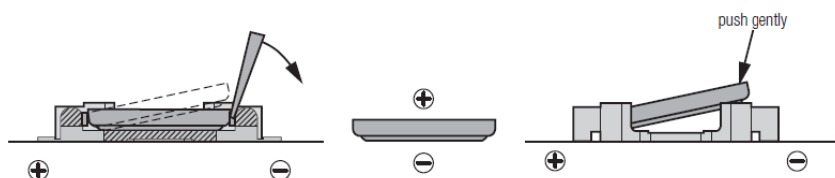

Safety guidelines

Underwriters Laboratories (UL) Safety Approval

Introduction

Safety approval of RENATA lithium products



Underwriters Laboratories Inc.

Northbrook/IL/USA

Recognition covers under the file number

MH14002 the following RENATA Lithium products:

Coin cells

CR1025, CR1216MFR, CR1220MFR, CR1225, CR1616, CR1620, CR1632, CR2016.MFR, CR2016MFR, CR2025.MFR, CR2025MFR, CR2032.MFR, CR2032MFR, CR2320, CR2325, CR2430, CR2450N, CR2450N-MFR CR2477N.

These cells may have an additional two-letter suffix which denotes type of solder tab or wire lead, or the mode of packaging or an additional letter and three digits suffix which denotes type of solder tab or wire lead.

Conditions of Acceptability

The use of these cells may be considered generally acceptable under the conditions given below:

1. The cells are identified in accordance with «Marking» as described below.
2. Unless the conditions of Par. 2A are met, these batteries are to be used only in devices where servicing of the battery circuit and replacement of the lithium battery will be done by a trained technician.
 - 2.A All of these batteries are acceptable for use in user-replaceable applications when used in accordance with the following except for Model CR2477N:
 - 2.A.1 The end product must be designed to prevent reverse polarity installation of the battery, or if the battery is reversed, the short- or open circuiting of any protective component, one component at a time, shall not result in forced discharge of the battery.
 - 2.A.2 The end product shall contain a warning notice adjacent to the battery stating the following: «Replace Battery with (Battery Manufacturer's Name or End-Product Manufacturer's Name), Part No. () Only. Use of another battery may present a risk of fire or explosion. See owner's manual for safety instructions».
 - 2.A.3 The instruction manual supplied with the end product shall also contain the above warning notice along with instructions to the user as to where replacement batteries can be obtained. The instruction manual shall also contain the following additional warning notice: «WARNING, Battery may explode if mistreated. Do not recharge, disassemble or dispose of in fire.»
3. These cells are intended for use at ordinary temperatures where anticipated high temperature excursions are not expected to exceed 100 °C (212 °F).
4. These cells can be used in series up to a maximum of four cells of the same model number. When used in series, there should be instructions adjacent to the cells stating that when the cells are replaced, they should all be replaced at the same time using fresh cells only. These cells should not be connected in series with any other (other than the allowed number of cells in series) power source that would increase the forward current through the cells.

Safety guidelines

Underwriters Laboratories (UL) Safety Approval

5. The circuit for these cells shall include one of the following:
- A Two suitable diodes or the equivalent in series with the cells to prevent any reverse (charging) current. The second diode is used to provide protection in the event that one should fail. Quality control, or equivalent procedures, shall be established by the device manufacturer to insure the diode polarity is correct for each unit, or
 - B A blocking diode or the equivalent to prevent reverse (charging) current, and in the event of diode failure, the cells shall be further protected against reverse (charging) current in excess of the values shown below. The measurement of this current shall include appropriate abnormal tests.

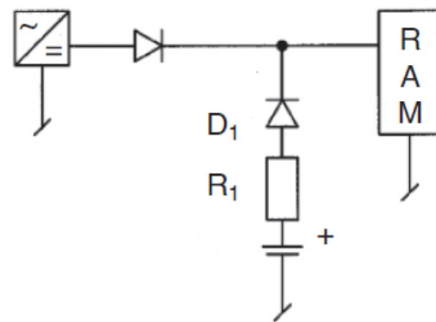
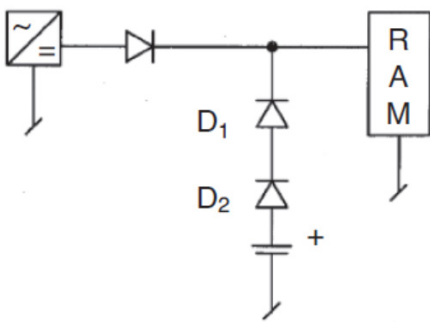

When D_1 is shorted D_2 still protects battery against recharging

R_1 limits the recharging current when D_1 fails

Note: An additional voltage drop over D_2 or R_1 must be considered when battery is operating.

Model No.	Max. Abnormal charging current (mA)	User replaceable
CR1025	5.0	Yes
CR1216 MFR	5.0	Yes
CR1220MFR	10.0	Yes
CR1225	25.0	Yes
CR1616	25.0	Yes
CR1620	25.0	Yes
CR1632	25.0	Yes
CR2016 MFR	10.0	Yes
CR2025 MFR	10.0	Yes
CR2032 MFR	10.0	Yes
CR2320	25.0	Yes
CR2325	25.0	Yes
CR2430	25.0	Yes
CR2450N	25.0	Yes
CR2477N	25.0	No

Safety guidelines

UL Safety tests

Abnormal Charging Test

The cells were charged by being connected in opposition with a 12 V dc power supply. The current was controlled by connecting a resistor of the appropriate size in series with the cell. The test duration was based on the applied current and the capacity of the cells.

The cells were examined after these tests for any sign of change.

Five samples of CR2450N in the as-received condition were used in these tests.

Results – None of the cells leaked. There were no fires or explosions as a result of tests at currents below 100 mA for the abnormal charging mode.

Crush Tests

The cells were crushed between a flat surface and a cylindrical surface having a radius of curvature of 5/16 in. The force was applied by means of a hydraulic ram and the cells were crushed until the thickness at the point of maximum crushing was less than one-fourth of the original cell thickness. The temperatures on the exterior surface of the metal cell casing was monitored by means of an iron-constantan thermo-couple. The cells were examined after the test for any signs of reaction due to the crushing.

Results – The casings opened and leaked as a result of this test. There was no temperature increase or any other adverse reaction as a result of this test.

Explosion Test

A cast aluminum chamber, 6 in. in diameter and 12 in. high with a 3/4 in. vent opening, was used for the test. Iron flanges were attached to both ends of the chamber. A solid 0.020 in. steel plate and a second thicker reinforcing steel plate with a 4 in. diameter hole in the center were bolted together to the bottom flange. Each sample cell tested was placed in turn in the chamber and centered on the bottom plate. Steel plates weighing 30 lb. were placed on top of the chamber. A 1 1/2 in. diameter Meker burner was ignited and placed under the chamber. The chamber was heated until the test cell exploded. Five CR2450N cells were used in these tests.

Results – Model CR2450N did not explode, however a fire did occur inside the explosion chamber.

Fire Exposure Tests

One sample was placed on a wire screen directly above a 2 in. diameter laboratory Meker burner fueled by methane gas at a pressure of 0.5 psig and a flow rate of 3.0 ft³/h. The cells were heated until they exploded or until ultimate results were obtained. For protection and also to muffle the sound of any explosions, the cells were tested in a room separate from the observer. The results of this test were used to determine if further testing would be needed to evaluate the fire exposure hazard of these cells. Five fresh cells were used in this test.

Results – Model CR2450N exploded. Based on these results, the Explosion Test was deemed necessary.

Puncture and Leaking Test

Cells were punctured by cutting through the cell casing with a small grinding wheel until liquid or gas was released from the cell. The cells were found to contain only a few drops of an organic liquid.

Results – The cells were not pressurized and no gas, liquid or solid particles were sprayed from the cells.

Safety guidelines

UL Safety tests

Short circuit test

The cells were shorted by connecting the positive and negative terminals with a short length of copper wire. The temperature on the exterior surface of the metal cell casing was monitored during the test by means of an iron-constantan thermocouple. Short circuit tests were conducted on cells at room temperature. After the tests, the cells were examined for any signs of change.

The following CR model was used in these tests:

Model CR2450N	
Previous conditioning of cells	Number of cells at room temperature
Fresh cells	5

Results – There were no signs of case bulging, leaking, or any other visible changes. The maximum temperature measured on the exterior surface of the metal cell casings was 30 °C (86 °F) for the tests conducted at room temperature.

Temperature cycling

Eighteen coin cells of each CR2032 and CR2430 were left in following conditions. The cells were exposed to alternate temperatures of +20 °C and +100 °C. In order to determine remaining capacity, the batteries were subjected to these temperatures in 60 cycles of two hours each and then discharged over a load of 8.25 kΩ down to 2 volts.

Results – The cells showed no visible change as a result of the temperature cycling.

Safety guidelines

Disposal of used batteries

The disposal of used batteries is governed by law in many countries world-wide. Therefore, please check your local regulations prior to battery disposal.

Safety Precautions for disposal of used batteries.

Safety precautions for the handling and storage of used lithium batteries.

Lithium batteries are a powerful energy source and require some caution even if almost fully discharged. When disposing of large quantities of lithium coin cells it is necessary to take certain safety measures in order to avoid heat generation and the danger of fire due to mass short-circuiting:

1. The number of lithium coin cells to be disposed of and placed in the same container during a day should be limited (if possible less than 100 pieces per day).
2. The container for disposal should be made of metal, not exceed a volume of 10 liters, be closed with a cover and have air holes in the upper area of the sidewalls.
3. For the storage of these containers, the following safety rules should be observed:
 - Containers to be stored outdoors, protected from rain, at least 2–3 meters away from buildings.
 - Distance between containers at least one meter.
 - Storage area not accessible to unauthorized persons.
4. It is recommended to mix the batteries in the containers daily for one week in order to ensure complete discharge and prevent the battery waste from heating up at a later stage.

As indicated above, these safety measures are only necessary if relatively large quantities of lithium batteries must be disposed of at the same time. In the retail/consumer trade, where only single batteries are changed and used batteries of different kinds are mixed together, there is no risk of battery waste heating up dangerously.

Rechargeable lithium-ion polymer batteries guidelines

Charging scheme

Lithium polymer batteries should be recharged at a constant current of 0.5 C (standard charge) up to a constant current of 1.0 C (fast charge), until a voltage of 4.2 V, followed by a constant voltage step at 4.2 V until the current falls to 0.05 C. The temperature range for a standard charge is between 0 °C and 45 °C, but 23 °C is recommended for optimal longevity of the cell. The characteristic of the battery during charge is shown below:

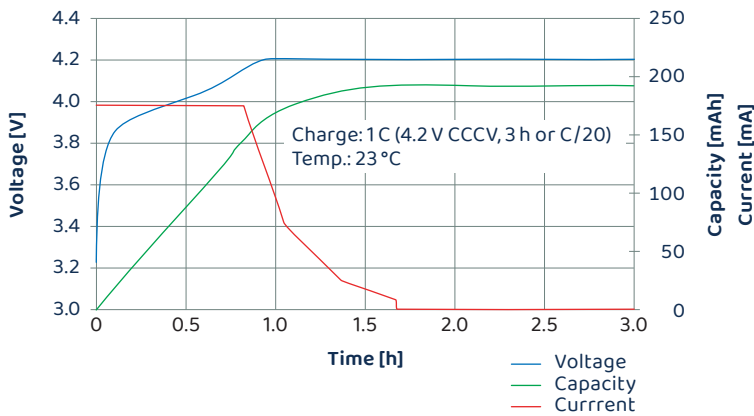

However, normal charging is not allowed if the battery is over-discharged. Over-discharging triggers the protection circuitry module (PCM) into protection mode and opens the switch to isolate the battery from the outside world. Therefore, it is important to measure the voltage of the battery before recharge. If no voltage can be measured, or if the voltage is below 3.0 V, do not charge the battery. For more details please see the section «Calendar Life» below.

Discharging scheme

Depending on the design, lithium-ion batteries can be discharged up to 2 C, but discharging at 0.5 C is recommended. Regardless of the discharge rate or the maximum charging voltage, discharge should be stopped at 3.0 V. For applications where the battery will be discharged at high currents, the battery will heat up. If the temperature increases too much, above 60 °C, the battery will likely to be damaged. Therefore, it is recommended, for these applications, that a PCM with temperature measurement capabilities is selected. The device should monitor the temperature of the battery to make sure that it is not overheated. The discharge characteristics is shown in the chart below:

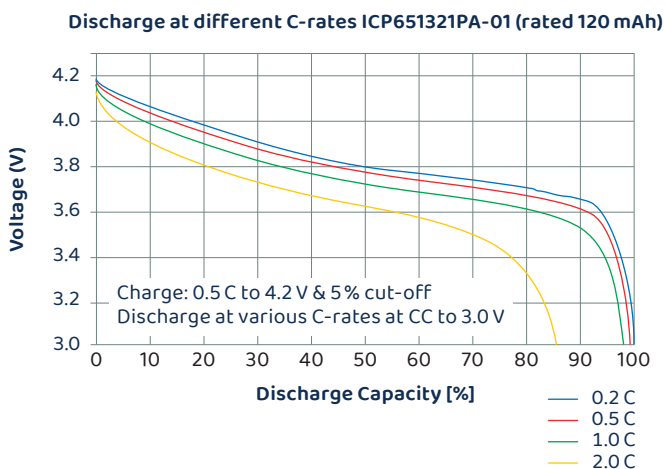

Rechargeable lithium-ion polymer batteries guidelines

Life of the battery

Cycle life and testing

Typical cycle tests of lithium batteries are done using $C/2$ currents for both charge and discharge at room temperature, with a rest period inserted between the charge and discharge process. The standard acceptance criterion is that a battery must provide $> 80\%$ of the original capacity after 300 cycles.

Note: RENATA sells rechargeable lithium polymer batteries with cobalt oxide, and in some cases other oxides, as the main cathode active material. There are other type of lithium batteries that can be cycled for thousands of cycles. However, these batteries typically have lower operating voltage, thus lower energy density, than RENATA products.

The cycle life of lithium batteries is affected by these factors:

- Charge and discharge conditions
Lithium batteries will have longer cycle life when the current is lower. Also, the life will be longer if the extent of the cycles are narrower. In other words, when the battery is not charged or discharged fully it can be operated for more cycles.
- Temperature: The best temperature range to operate the battery is between 0 and 45 °C.

Calendar life (Self-Discharge)

Lithium battery loses its capacity during storage, caused by the electrolyte decomposition, lithium-ion re-insertion into the cathode, or contamination from impurities.

The self-discharge rate depends on several factors:

- Temperature: at higher temperature the reaction rate is higher, and the battery will lose its capacity faster.
- PCM: The PCM is used to protect the battery from going into dangerous territories if being charged or discharged inappropriately. The PCM monitors the voltage and current (and optionally the temperature) of a battery continuously. For this reason, it consumes current continuously, typically between 2 to 5 μA . This is higher than the self-discharge rate of the battery by itself. Therefore, if a battery is installed with a PCM, it is very important to recharge the battery within 6 months of receiving the battery. For smaller batteries with capacities less than 60 mAh, this recharge period shall even be reduced.
- Charge level: A lithium battery by itself, i.e. without a PCM, has the lowest self-discharge rate at about 30% state of charge (SOC). At this state the open circuit voltage (OCV) is between 3.7 and 3.8 V and the self-discharge current is about 1 μA or less. On the other hand, when the SOC is higher, at 100%, or fully charged state, the discharge current can be about 4 μA . In general, the self-discharge rate for a battery alone is lower than the current consumption of the PCM. Therefore, when calculating how long the battery can be stored, the current consumption of the PCM must be considered.

Rechargeable lithium-ion polymer batteries guidelines

Due to self-discharge, the energy content of a battery decreases continuously, and it is important to make sure that the voltage does not fall below 3.0 V. If the battery is allowed to discharge past 2.5 V (or whatever the over-discharge protection voltage is), it would trigger the PCM to open the safety switch and isolate the battery from the outside. When this happens, please do not recharge and stop using the battery.

The effect of self-discharge can be seen in the chart below:

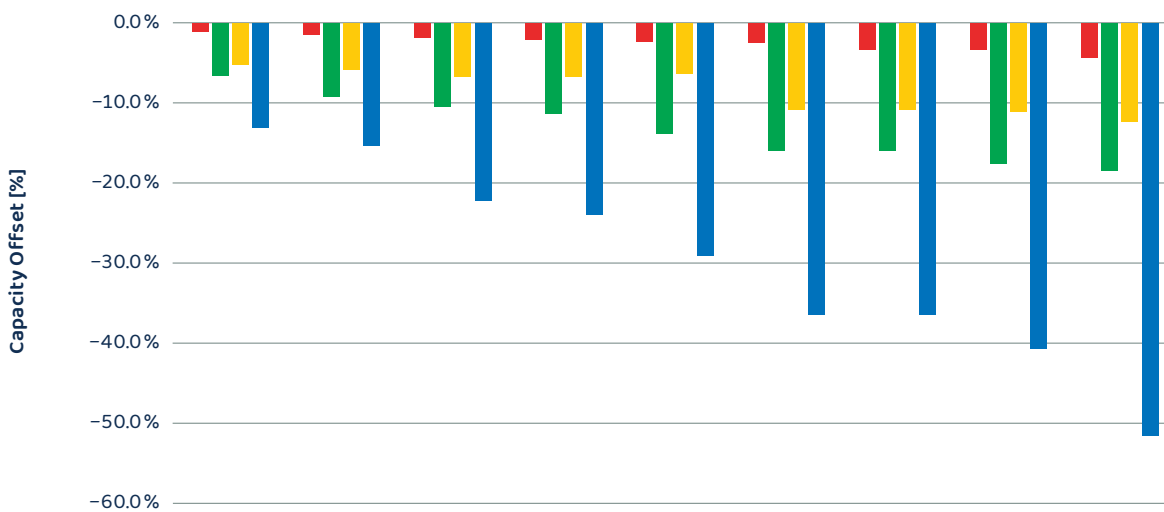

	1 Month	2 Months	3 Months	4 Months	5 Months	6 Months	9 Months	12 Months	18 Months
25 C - 50% SOC	-1.2%	-1.6%	-1.9%	-2.2%	-2.4%	-2.5%	-3.4%	-3.5%	-4.4%
25 C - 100% SOC	-6.7%	-9.3%	-10.6%	-11.3%	-14.0%	-15.8%	-15.8%	-17.6%	-18.4%
40 C - 50% SOC	-5.3%	-5.9%	-6.7%	-6.7%	-6.4%	-10.9%	-10.9%	-11.1%	-12.4%
40 C - 100% SOC	-13.2%	-15.4%	-22.2%	-23.9%	-29.0%	-36.4%	-36.4%	-40.7%	-51.5%

Housing considerations

Lithium-ion batteries can be charged and discharged repeatedly for hundreds, if not thousands of cycles. It is important to recognize that the thickness of the battery will increase during charge, and reduce during discharge. Furthermore, as the battery ages, it gradually grows thicker compared to the fresh state. In general, the thickness increases about 3%–5% between charge and discharge. Throughout its life, the thickness may increase up to 7% after 300 cycles.

Because the thickness is not a constant, it should be noted that, when designing the battery chamber in the application, extra room should be provided to avoid any compression on the battery through its life. Furthermore, there must not be any sharp points pressing on the surface of the battery. These sharp points may create heavy pressure on the battery when it swells and damage the packaging material, leading to unsafe conditions such as leakage of the electrolyte, short-circuiting, or even fire.

Uneven pressure on the battery surface, however small it is, will disturb the uniformity of reactions and reduce the service life of the battery.

Rechargeable lithium-ion polymer batteries guidelines

Internal resistance

Lithium batteries generate energy by the electrochemical reactions of their active materials. The process involves electron movement in conductive materials, ionic transfer through a liquid medium, and reactions of the two active materials.

Therefore, the internal resistance is not a constant, but changes as the internal state of the battery changes.

Measurement methods

There are two general methods to measure the internal resistance of a battery: AC method and DC method.

- AC Method: A small AC current is applied to the battery and the voltage of the battery is measured. The resistance is calculated by dividing the voltage change by the current change. Because the current is not a constant, the rate it changes, or the frequency of the AC signal, also affects the measurement results. Scientists use this method to analyze different components of the internal resistance of the battery. For example, the resistances generated by the current collectors, by the movement of lithium-ions, and that for the electrochemical reactions.

Because the input current is small and include both positive and negative values (discharge and charge of the battery), it does not change the SOC of the battery during the measurement. Furthermore, the measurement is quick if the frequency is fixed at a high value, such as 1 kHz. Therefore, it is popular for battery manufacturers to use this method to report the internal resistance of a battery.

- DC Method: The battery is discharged by a DC current for a short period of time and the OCV and the CCV is measured. The resistance is calculated from the differences in voltage and current, before and during the current pulse.

The DC method is more practical for the user of the battery because the measurement can be done using the same condition in the application. The measured resistance represents the actual behavior of the battery under the application. It should be noted that, because the CCV of the battery decreases during the measurement, changing the measurement time will change the value of the resistance.

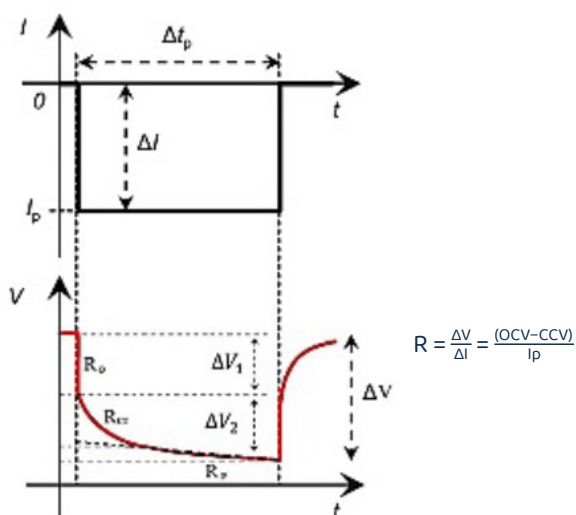

Rechargeable lithium-ion polymer batteries guidelines

Functions of safety circuit

Rechargeable lithium-ion polymer batteries usually come with an integrated safety circuit, or protective circuitry module (PCM). This safety circuit provide the following functions:

- Operating input voltage: 1.5–12 V
- Current consumption (during operation): 2–5 μ A
- Current consumption (when powered down): 0.05–0.1 μ A
- Over-charge threshold voltage: 3.5 to 4.6 V selectable, typical 4.3 V
- Over-charge release voltage: 4.0 to 4.3 V selectable, typical 4.225 V
- Over-discharge voltage protection: 2.0 to 3.4 V selectable, typical 2.5 V
- Over-discharge release voltage: 2.3 to 3.0 V selectable, typical 2.9 V
- Temperature measurement: typically done by NTC
- Sleep mode (optional)
- 0 V battery charge function

For more detailed information, please refer to the product specification sheet of the battery.

Nomenclature

- OCV – The static voltage when the circuit is open and the battery is not being charged or discharged.
- CCV – The voltage when the circuit is closed and the battery is being discharged or charged.
- SoC – State of Charge, a percentage value representing the amount of capacity left in the battery. 100% SoC stands for fully charged state, and 0% fully discharged state.
- R_i – Internal resistance.
- PCM – Protection Circuitry Module

Quality management system

When RENATA first started as a supplier of batteries to the Swiss watch industry, it developed a high level of quality consciousness. «**Quality comes first**» rules at every level of the enterprise.

RENATA's quality management system is certified according to the ISO 9001 standard.

The basis for providing our worldwide customers with top quality products is our continuous product and process improvement.

The open circuit voltage (OCV), closed circuit voltage (CCV) and mechanical dimensions of every single RENATA lithium battery are checked individually.

Batteries only leave our factory after a mandatory **storage period (quarantine) of at least 3 weeks.**

During this period of time, extensive performance testing is done.

This testing comprises:

- Various leakage resistance tests
- Shelf life tests
- Storage under varying atmospheric conditions (artificial aging)
- Discharge tests to monitor capacities
- Electrical characteristic testing (voltage, internal resistance, etc.)
- Visual checks, including internal components of dismantled batteries

The flow chart on next page shows the main production steps and the integrated quality control procedures for RENATA lithium batteries.

The controls on the product are the following (see process flow chart on the next page):

1. Statistical control («Quality tests» step) performed for every batch, consisting of
 - a. Discharge capacity check
 - b. Leakage tests
2. After the Quality tests are successfully completed, 100% of each batch is controlled in terms of OCV, internal resistance (resistive load method) and height («Final control 100%» step).
3. If the battery is tabbed, after the tab welding 100% of each batch is re-controlled in terms of OCV, internal resistance (resistive load method; «Battery tabbing 100% electrical and tags» step).

Process for the production of lithium metal coin cells

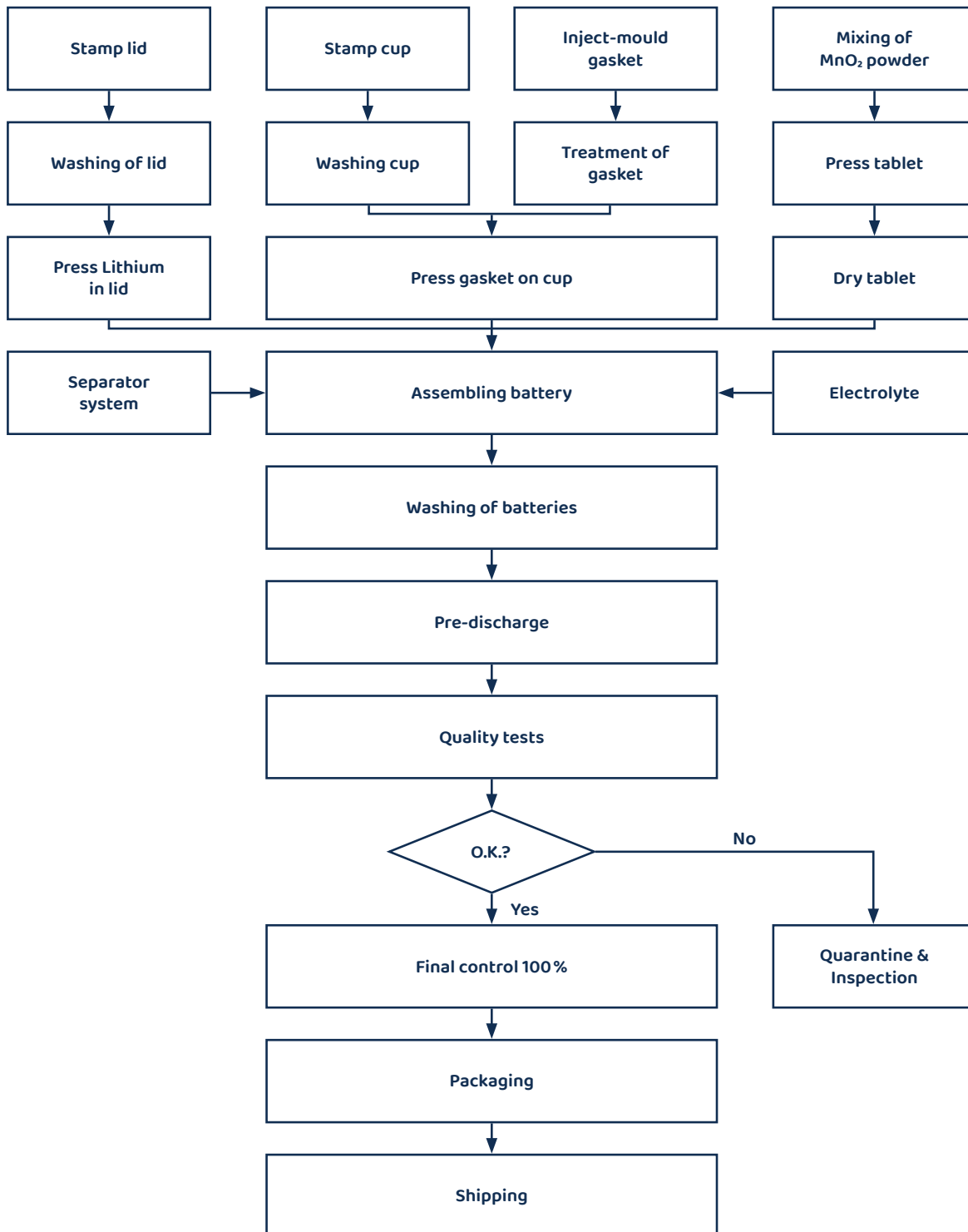

Certificates and declarations

UL Safety Approval

You can see the certificates for Underwriters Laboratories Inc. Safety Approval at the UL Online Certifications Directory website. For that, click «Certifications» on www.ul.com and search for «Company Name»: RENATA. RENATA's coin cells and Power Modules are listed under file no. MH14002.

Certificates and declarations

Conformity with battery directive 2006/66/EC

Link: [CERTIFICATE OF COMPLIANCE Battery Directive](#)

the swiss power source



CERTIFICATE OF COMPLIANCE

with EU Battery Directive 2006/66/EC from 6 September 2006
and its amendment (Dir. 2008/12/EC, 2008/103/EC, 2013/56/EU)

Renata SA's range of 3V Lithium Manganese Dioxide coin cells:

Renata CR1025 ¹⁾	Renata CR2016.MFR ⁸⁾	Renata CR2320 ¹⁾
Renata CR1216 ¹⁾	Renata CR2025 MFR ²⁾	Renata CR2325 ¹⁾
Renata CR1216 MFR ⁸⁾	Renata CR2025 ¹⁾	Renata CR2430 ¹⁾
Renata CR1220 ¹⁾	Renata CR2032 MFR ²⁾	Renata CR2430 MFR ⁶⁾
Renata CR1220 MFR ⁸⁾	Renata CR2032 ¹⁾	Renata CR2450N ¹⁾
Renata CR1225 ¹⁾	Renata CR2032.MFR ¹⁰⁾	Renata CR2450N.MFR ¹¹⁾
Renata CR1616 ¹⁾	Renata CR2045 ³⁾	Renata CR2450HT ⁴⁾
Renata CR1620 ¹⁾	Renata CR2025.MFR ⁸⁾	Renata CR2477N ¹⁾
Renata CR1632 ¹⁾	Renata CR2045HT ⁴⁾	Renata CR2450N-MFR ⁷⁾
Renata CR2016 MFR ²⁾	Renata CR2046A ⁴⁾	Renata CR2477N.MFR ¹²⁾
Renata CR2016 ¹⁾		

This document certifies that the battery models as stated above and provided by Renata SA are in compliance with the above mentioned EU Battery Directive.
January 11, 2021



Eric Weber CTO

Weight limits according to 2006/66/EC

Substance	Weight limit (ppm)
Lead (Pb)	40
Cadmium (Cd)	20
Mercury (Hg)	5

Applicability of RoHS / WEEE / End of Life Vehicles Directives on Batteries:

- The RoHS Directive**
Directive 2011/65/EU (including amendment 2015/863/EU) of the European Parliament and of the Council of June 08, 2011 on the restriction of the use of certain hazardous substances in electrical and electronics equipment (RoHS Directive). → does not apply to batteries. (see preamble 14 of this directive)
- The WEEE Directive**
Directive 2012/19/EU of the European Parliament and of the Council of 4 July 2012 on waste electrical and electronic equipment (WEEE Directive) (including amendment 2018/849/EU).
→ does apply to batteries and requires their removal and separate collection.
Once removed from WEEE, used batteries are governed by the Battery Directive 2006/66/EC.
- The "End of Life Vehicles" Directive**
Directive 2000/53/EC of the European Parliament and of the Council of September 18, 2000 on end of life vehicles (including amendment 2018/849/EU).
→ Does apply to batteries and requires their removal before treatment operations for depollution of end-of-life vehicles:
→ Once removed from end of life vehicle, used batteries are governed by the Battery Directive 2006/66/EC.

Renata SA
CH-4452 Itingen/Switzerland

Tel. +41 (0)61 975 75 75
Fax. +41 (0)61 975 75 95

sales@renata.com
www.renata.com

Rev 22 / January 11, 2021

A COMPANY OF THE  SWATCH GROUP

Certificates and declarations

Conformity with RoHS (bare batteries)

Link: [CERTIFICATE OF COMPLIANCE RoHS2](#)

the swiss power source



**CERTIFICATE OF COMPLIANCE with Directive 2011/65/EU
RoHS (recast) in its current consolidated version: 01/11/2021**

This document certifies that the components listed below and manufactured by RENATA SA are in compliance with the weight limits^[1] listed in the

- Directive 2011/65/EU in its current consolidated version: 01/09/2020 of the European Parliament on the Restriction of the use of certain Hazardous Substances in electrical and electronic equipment (**RoHS recast**). The batteries themselves - when separated - are covered by the directive 2006/66/EC of 6 September 2006 (EU **Battery Directive**).
- "Requirements for concentration limits for certain hazardous substances in electronic information products SJ/T11363-2006" (**CHINA RoHS**)
- EFUP Label 

RENATA Product	Part/Product Description	SGS reports no.
All battery holders with appendix "-LF"	Battery holders (SMTU / HU series)	CANEC1621283303 Dated November 04, 2016
	Battery holders (NH, NL types)	CANEC1621283305 Dated November 04, 2016
Battery holder NL-LF modified Rivet length	NL5077-LFRS	CANEC1621283305 Dated 11.04.16 Rivet: SHAEC1905250201 Dated: 26.03.19
Battery holder SMTU (Gold contact)	SMTU2032-G	CANEC1621283301 Dated November 04, 2016
Battery holder HU (Gold contact)	HU2032-G	Manufacturer declaration
Battery holder VBH type	VBH2032-1	CANEC1621283304 Dated November 04, 2016
Battery holder SMTM series	Battery holders (SMTM type)	Manufacturer declaration
Battery Holder SMTU series with appendix "-C"	Surface Mounting Clip	CANEC1621283302 Dated November 04, 2016

This document also certifies that the declaration of materials as been provided by RENATA SA is accurate. This certificate is provided to the best of our knowledge and belief, and based on our current level of knowledge.

RENATA SA

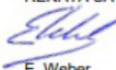

E. Weber
CCO

Itingen, May 12, 2022

^[1]Weight limits according to 2011/65/EU, Amendment 2015/863/EU Annex 2

#	Substance	Weight limit (ppm)
1	Lead (Pb)	1000
2	Cadmium (Cd)	100
3	Mercury (Hg)	1000
4	Hexavalent chromium (Cr ⁶⁺)	1000
5	Polybrominated biphenyls (PBB)	1000
6	Polybrominated diphenyl ethers (PBDE)	1000
7	Bis(2-ethylhexyl) phthalate (DEHP)	1000
8	Butyl benzyl phthalate (BBP)	1000
9	Dibutyl phthalate (DBP)	1000
10	Diisobutyl phthalate (DIBP)	1000

Restricted substances referred to in Article 4 and maximum concentration values tolerated by weight in homogeneous materials

Renata SA
CH-4452 Itingen/Switzerland

Tel. +41 (0)61 975 75 75
Fax. +41 (0)61 975 75 95

sales@renata.com
www.renata.com

A COMPANY OF THE  SWATCH GROUP
Rev 15c / May 12, 2022

Certificates and declarations

Mercury free products

Links:

- COC Hg free Silver oxide with EU battery directive – [COC EU Battery Directive 2006/66](#)
- COC Hg free Silver oxide with China RoHS – [2019-09-19 COC Hg free Silver Oxide China RoHS2 bare batteries](#)
- COC 3V Lithium with 0 Mercury content – [CERTIFICATE OF COMPLIANCE CR 0% Hg](#)

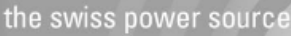



CERTIFICATE OF COMPLIANCE
with 0% Mercury content

Renata SA's range of 3V Lithium Manganese Dioxide coin cells:

Model	Country of Origin	Model	Country of Origin
Renata CR1025	Switzerland	Renata CR2032 MFR	Indonesia
Renata CR1216 MFR	Indonesia	Renata CR2320	Switzerland
Renata CR1220 MFR	Indonesia	Renata CR2045	Switzerland
Renata CR1225	Switzerland	Renata CR2325	Switzerland
Renata CR1616	Switzerland	Renata CR2430	Switzerland
Renata CR1620	Switzerland	Renata CR2450N	Switzerland
Renata CR1632	Switzerland	Renata CR2450N-MFR	China
Renata CR2016 MFR	Indonesia	Renata CR2450HT	Switzerland
Renata CR2025 MFR	Indonesia	Renata CR2477N	Switzerland
Renata CR2016.MFR	China	Renata CR2025.MFR	China
Renata CR2032.MFR	China	Renata CR2450N.MFR	China
Renata CR2477N.MFR	China		

This document certifies that the battery models as stated above and provided by Renata SA contain

0% Mercury

Ittingen, August 27, 2019

Renata SA



Eric Weber
CTO

Renata SA
CH-4452 Ittingen/Switzerland

Tel. +41 (0)61 975 75 75
Fax. +41 (0)61 975 75 95

sales@renata.com
www.renata.com

Rev 08 August 27, 2019

A COMPANY OF THE  **SWATCH GROUP**

Certificates and declarations

Conformity with IATA, ICAO and DOT regulations

Transportation of lithium batteries

The transportation of lithium batteries is regulated by the International Air Transport Association (IATA), the International Civil Aviation Organization (ICAO) and by the U.S. Department of Transportation (DOT).

IATA and ICAO special provisions A45

All RENATA lithium batteries are considered as non-hazardous since they meet the Special Provisions A45, as published in IATA's handbook, 41st edition, and effective 1 January 2000.

These provisions require: «Batteries must be separated so as to prevent short circuits and must be packed in strong packaging, except when installed in electronic devices». All RENATA Li/MnO₂ cells or batteries have solid cathodes and contain less than 1 gram of lithium or lithium alloy.

Also, the batteries are approved in accordance to UN Special Provision SP 188-Manual of Tests & Criteria Part III Subsection 38.3.

DOT

All RENATA lithium batteries are not subject to the requirements of the DOT Subchapter C, Hazardous Material Regulations because all our batteries meet the requirements of 49 CFR173.185 (b). Material Safety Data Sheets (MSDS) of each reference are available on request.

Certificates and declarations

Conformity with IATA, ICAO and DOT regulations

Transportation of lithium batteries

Link:

- [Transportation manual](#)
- [ASDS Lithium metal](#)
- [ASDS Lithium metal thin-film](#)
- [ASDS Lithium-ion polymer batteries](#)

Certificates and declarations

Conformity with IATA, ICAO and DOT regulations

Transportation of lithium batteries

Lithium-ion Batteries are classified as Dangerous goods under Class 9 per the United Nations. Our cells and batteries are in compliance of the United Nation Transport Recommendations and meets all the requirements of UN Manual of Test and Criteria (IATA DGR 3.9.2.6). For transporting our cell or batteries, depending of the shipping method used, the dangerous goods regulations and/or rules are fulfilled and must be followed in case of further transportation. Our coin cells or batteries are packed and shipped under compliance of IEC 60086-1. Our original packaging are adequate to avoid mechanical damages during the transport, handling and stacking. The materials used prevent the development of unintentional electrical conduction, corrosion of the terminals and ingress of moisture, shock and vibration are kept to a minimum. For the transport, handling and storage the boxes must be handled with care – cartons should not be thrown off trucks, slammed into position or piled so high as to overload battery containers below. Protection from inclement weather should be provided.

IATA, ICAO and DOT special provisions for the international transportation

UN-No. UN 3480

Proper shipping name: Lithium-ion Batteries (including lithium polymer batteries)

Lithium-ion cells and batteries are subject to the following dangerous goods regulations/rules:

Shipping method	Dangerous goods regulation	Packing instruction and special provisions
Air Cargo aircraft only (Forbidden for transport aboard passenger aircraft)	ICAO TI 2020–2021 related to: IATA Dangerous Goods Regulations 2021 (62nd Edition)	Packing Instruction 965 Section II Applies for single package shipments with less than 2.5 kg total net weight. Shipper's Declaration (DGD) is not required. Packing Instruction 965, Section IB Applies for more than 1 package shipments. Each carton do not have to exceed more than 2.5 kg total net weight. (No limitation in the number of packaging per shipment) Shipper's Declaration
Road and rail Europe	ADR/RID 2021	Special Provision 188
Marine	IMDG Code 2020/2021 (amdt. 40–20)	Special Provision 188
USA	DOT 49 CFR	49 CFR Sections 171.12, 171.24, 171.25, 173.185

Certificates and declarations

Conformity with IATA, ICAO and DOT regulations

Summary of Transport Packing Instructions and Special Provisions of above mentioned Technical Guidelines:

1. For all lithium-ion and lithium polymer cells, listed in Annex I, the Watt-hour rating is not more than 2.7 Wh. Excepting Articles: ICP543759 (Watt-hour rating is 4.9 Wh) and ICP606168 (Watt-hour rating is 10.4 Wh).
2. For all the lithium-ion cells or batteries, listed in Annex I, are fully and successfully tested to meet the requirements of each test in the UN Manual of Tests and Criteria, Part III, subsection 38.3 – (IATA DGR 3.9.2.6).
3. Our cells are safe for transport when build-in equipment¹ (IATA – PI 967) or packed with equipment² (IATA – PI 966) shipped under UN 3481. Proper shipper name vary, see below:
 - UN No. IATA DGR – Proper Shipper Name IATA DGR – Packaging Instruction
 - UN3481 Lithium-ion battery contained in equipment 967
 - UN3481 Lithium-ion battery packed with equipment 966

Important: assembly of the cells and batteries is the responsibility of the customer and may make new safety tests related to devices necessary.

4. Packing, marking, labelling and weight limitations must be observed as per technical guidelines of the respective transport mode.
5. We hereby declare, that the state of charge (SoC) of the cells and batteries does not exceed a Rate of 30%

Certificates and declarations

Distributed by

RENATA SA
CH-4452 Itingen/Switzerland
Tel. +41 61 975 75 75
Fax +41 61 975 75 95
sales@renata.com
www.renata.com

